

Computer Graphics (CS 543)

Lecture 9: Shadows and Fog

Prof Emmanuel Agu

*Computer Science Dept.
Worcester Polytechnic Institute (WPI)*





Introduction to Shadows

- Shadows give information on relative positions of objects

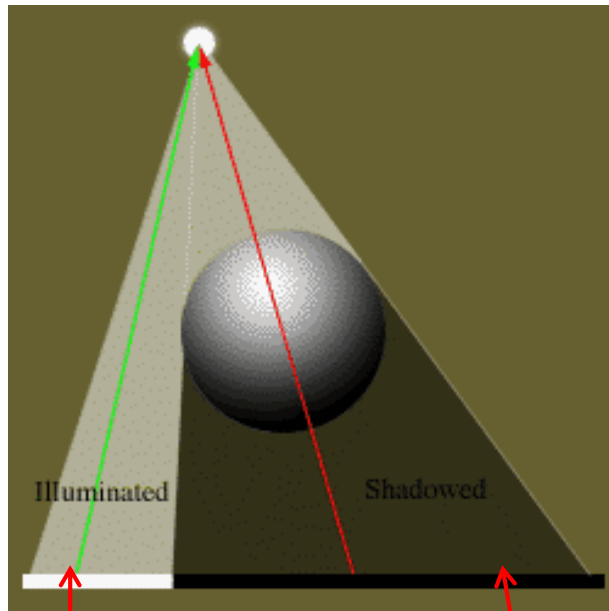

Use ambient +
diffuse + specular
components

Use just ambient
component

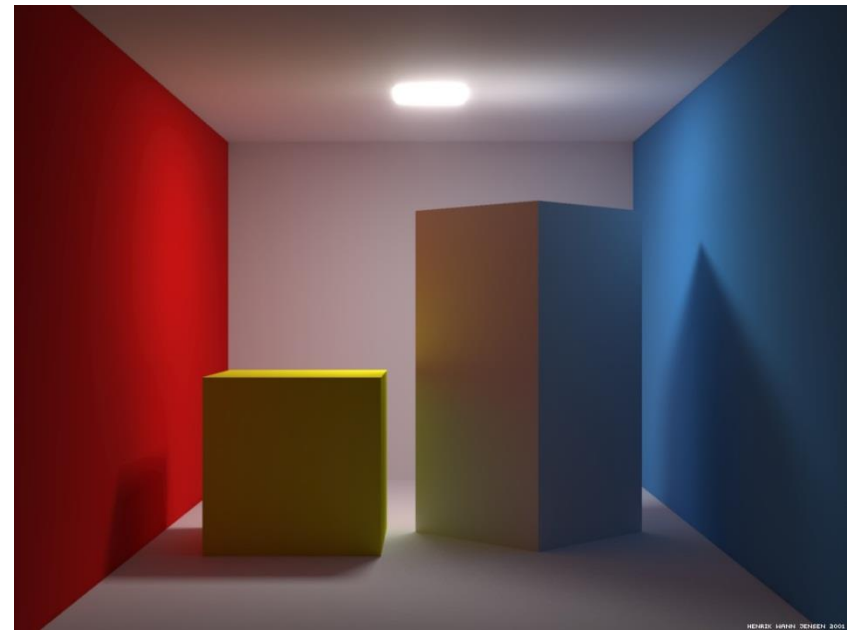



Why shadows?

- More realism and atmosphere



Image courtesy of BioWare





Types of Shadow Algorithms

- Project shadows as separate objects (like Peter Pan's shadow)
 - **Projective shadows**
- As volumes of space that are dark
 - **Shadow volumes** [Franklin Crow 77]
- As places not seen from a light source looking at the scene
 - **Shadow maps** [Lance Williams 78]
- Fourth method used in ray tracing



Projective Shadows

- Oldest method: Used in early flight simulators
- Projection of polygon is polygon called **shadow polygon**

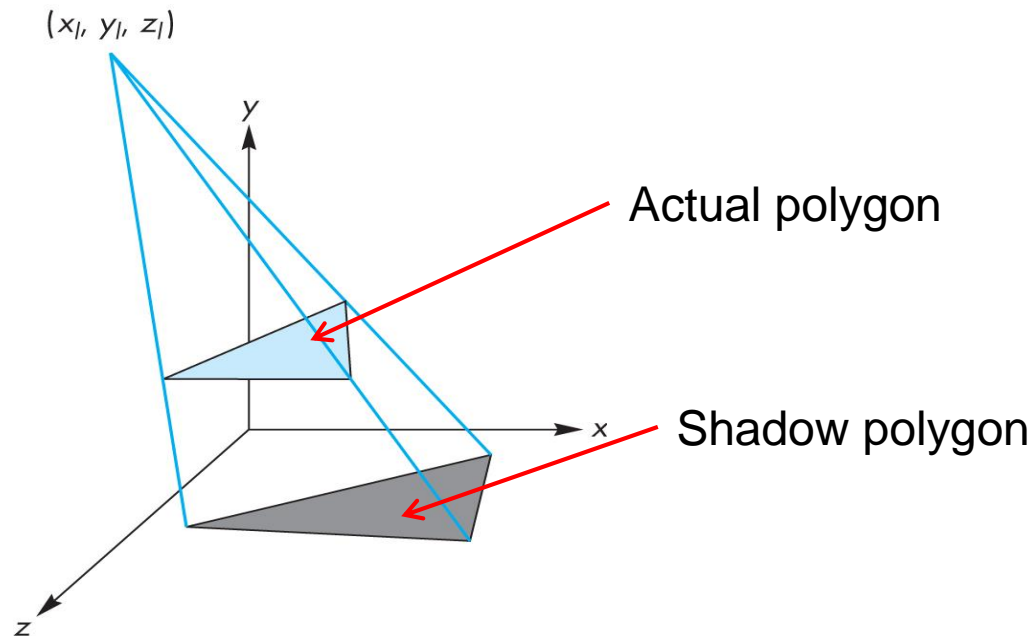



Projective Shadows

- Works for flat surfaces illuminated by point light
- For each face, project vertices \mathbf{V} to find \mathbf{V}' of shadow polygon
- Object shadow = union of projections of faces

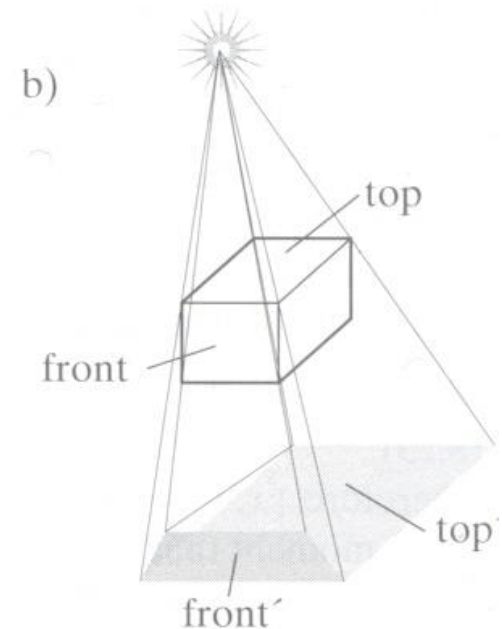
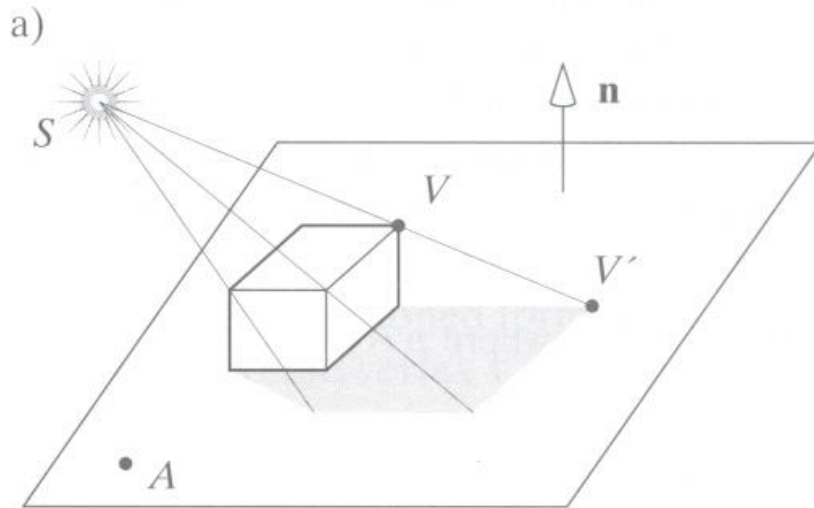



Projective Shadow Algorithm

- Project light-object edges onto plane
- Algorithm:
 - First, draw ground plane/scene using specular+diffuse+ambient components
 - Then, draw shadow projections (face by face) using only ambient component



Projective Shadows for Polygon

1. If light is at (x_l, y_l, z_l)
2. Vertex at (x, y, z)
3. Would like to calculate shadow polygon vertex V projected onto ground at $(x_p, 0, z_p)$

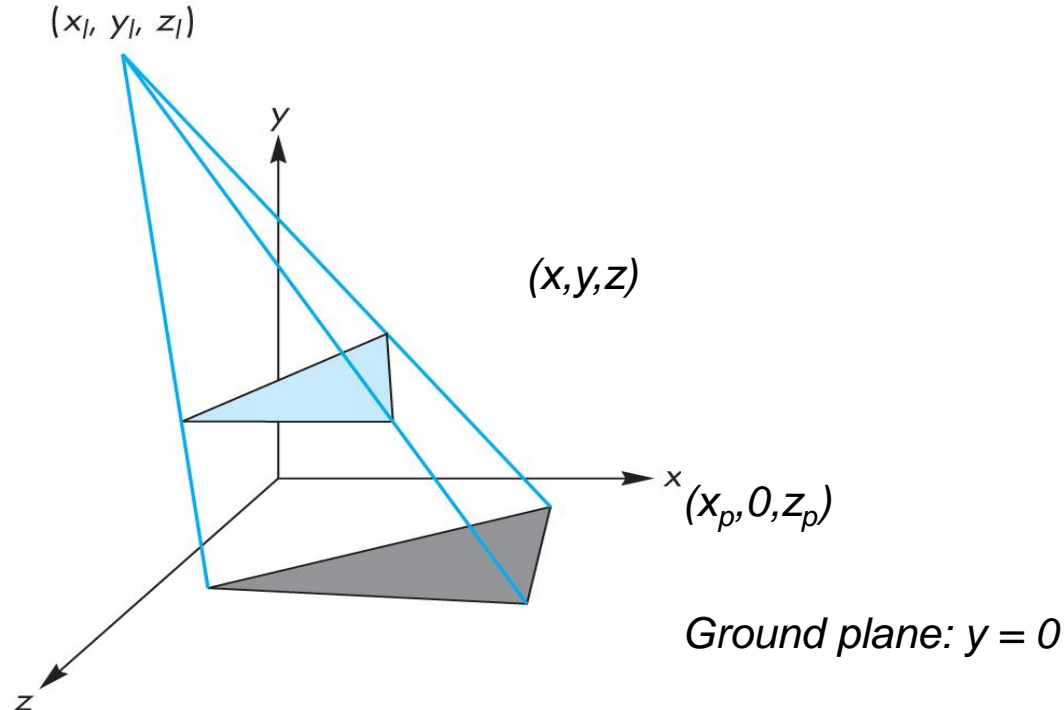



Projective Shadows for Polygon

- If we move original polygon so that light source is at origin
- Matrix M projects a vertex V to give its projection V' in shadow polygon

$$m = \begin{bmatrix} 1 & 0 & 0 & 0 \\ 0 & 1 & 0 & 0 \\ 0 & 0 & 1 & 0 \\ 0 & \frac{1}{-y_l} & 0 & 0 \end{bmatrix}$$

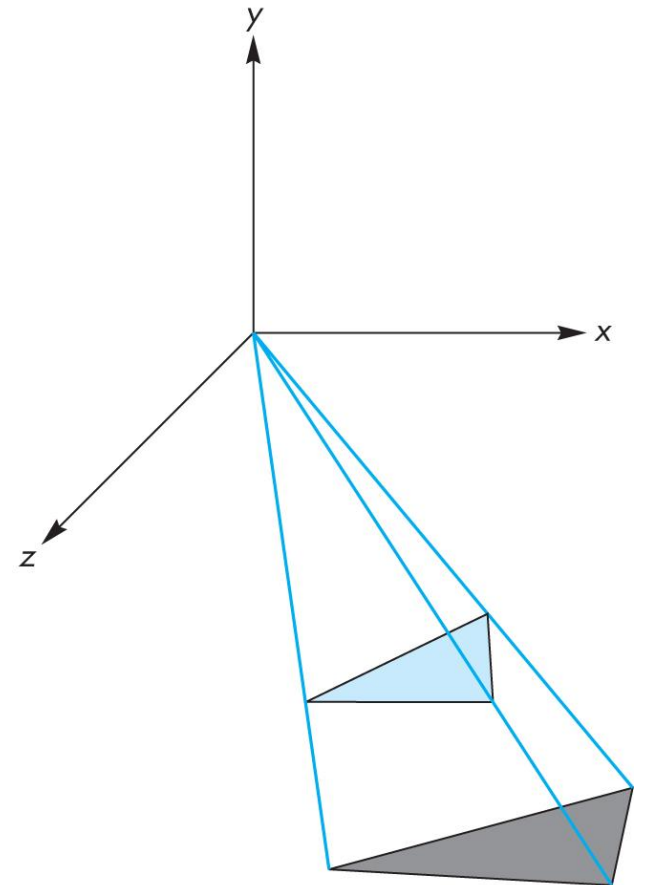



Building Shadow Projection Matrix

1. Translate source to origin with $T(-x_l, -y_l, -z_l)$
2. Perspective projection
3. Translate back by $T(x_l, y_l, z_l)$

$$M = \begin{bmatrix} 1 & 0 & 0 & x_l \\ 0 & 1 & 0 & y_l \\ 0 & 0 & 1 & z_l \\ 0 & 0 & 0 & 1 \end{bmatrix} \begin{bmatrix} 1 & 0 & 0 & 0 \\ 0 & 1 & 0 & 0 \\ 0 & 0 & 1 & 0 \\ 0 & \frac{1}{-y_l} & 0 & 0 \end{bmatrix} \begin{bmatrix} 1 & 0 & 0 & -x_l \\ 0 & 1 & 0 & -y_l \\ 0 & 0 & 1 & -z_l \\ 0 & 0 & 0 & 1 \end{bmatrix}$$

Final matrix that projects
Vertex V onto V' in shadow polygon



Code snippets?

- Set up projection matrix in OpenGL application

```
float light[3]; // location of light
mat4 m; // shadow projection matrix initially identity
```

```
M[3][1] = -1.0/light[1];
```

$$M = \begin{bmatrix} 1 & 0 & 0 & 0 \\ 0 & 1 & 0 & 0 \\ 0 & 0 & 1 & 0 \\ 0 & \frac{1}{-y_l} & 0 & 0 \end{bmatrix}$$



Projective Shadow Code

- Set up object (e.g a square) to be drawn

```
point4 square[4] = {vec4(-0.5, 0.5, -0.5, 1.0)}  
                  {vec4(-0.5, 0.5, -0.5, 1.0)}  
                  {vec4(-0.5, 0.5, -0.5, 1.0)}  
                  {vec4(-0.5, 0.5, -0.5, 1.0)}
```

- Copy square to VBO
- Pass modelview, projection matrices to vertex shader



What next?

- Next, we load `model_view` as usual then draw original polygon
- Then load shadow projection matrix, change color to black, re-render polygon

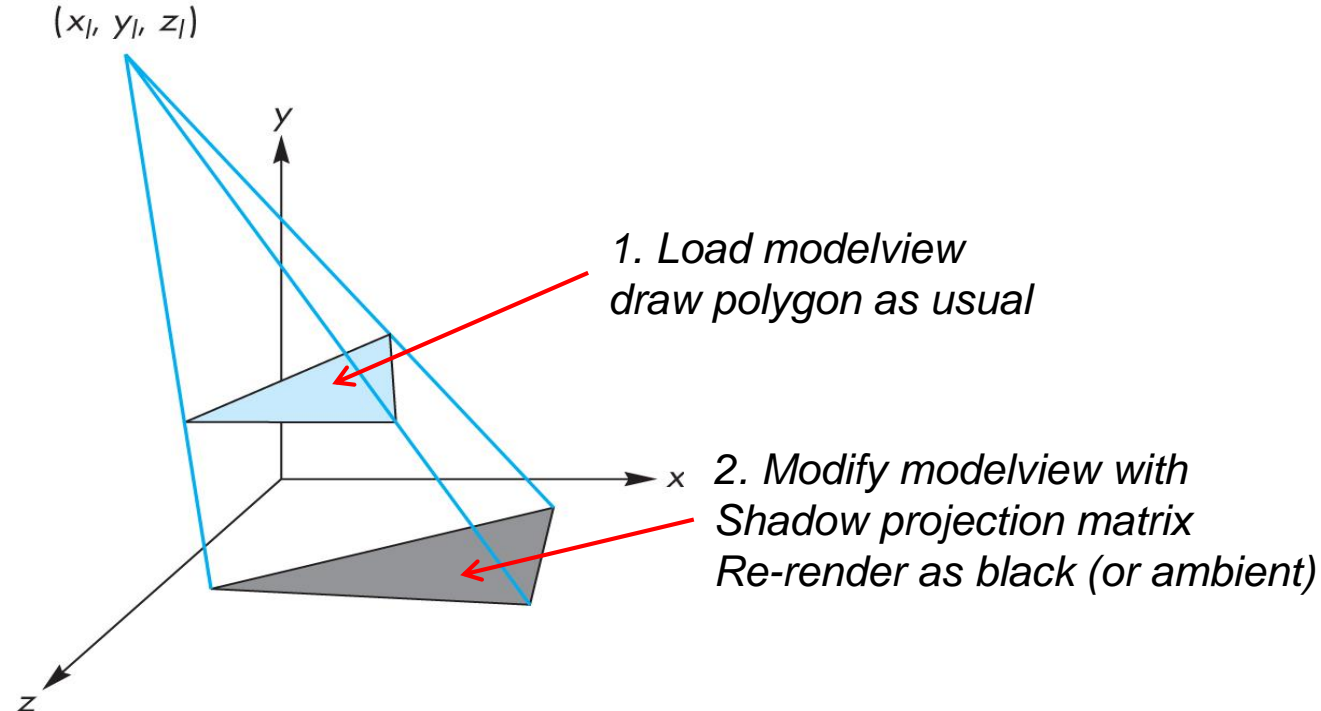

Shadow projection Display() Function



```
void display( )
{
    mat4 mm;
    // clear the window
    glClear(GL_COLOR_BUFFER_BIT | GL_DEPTH_BUFFER_BIT);

    // render red square (original square) using modelview
    // matrix as usual (previously set up)
    glUniform4fv(color_loc, 1, red);
    glDrawArrays(GL_TRIANGLE_STRIP, 0, 4);
}
```



Shadow projection Display() Function

```
// modify modelview matrix to project square
// and send modified model_view matrix to shader
mm = model_view
    * Translate(light[0], light[1], light[2])
    *m
    * Translate(-light[0], -light[1], -light[2]);
glUniformMatrix4fv(matrix_loc, 1, GL_TRUE, mm);

//and re-render square as
// black square (or using only ambient component)
glUniform4fv(color_loc, 1, black);
glDrawArrays(GL_TRIANGLE_STRIP, 0, 4);
glutSwapBuffers( );
}
```

$$M = \begin{bmatrix} 1 & 0 & 0 & x_l \\ 0 & 1 & 0 & y_l \\ 0 & 0 & 1 & z_l \\ 0 & 0 & 0 & 1 \end{bmatrix} \begin{bmatrix} 1 & 0 & 0 & 0 \\ 0 & 1 & 0 & 0 \\ 0 & 0 & 1 & 0 \\ 0 & \frac{1}{-y_l} & 0 & 0 \end{bmatrix} \begin{bmatrix} 1 & 0 & 0 & -x_l \\ 0 & 1 & 0 & -y_l \\ 0 & 0 & 1 & -z_l \\ 0 & 0 & 0 & 1 \end{bmatrix}$$



Fog



Fog example

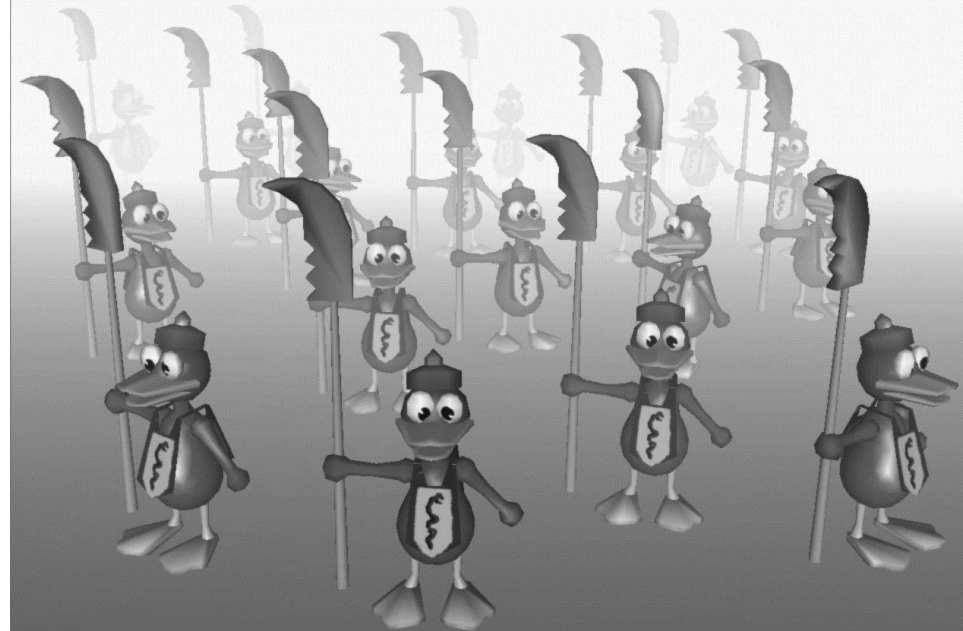
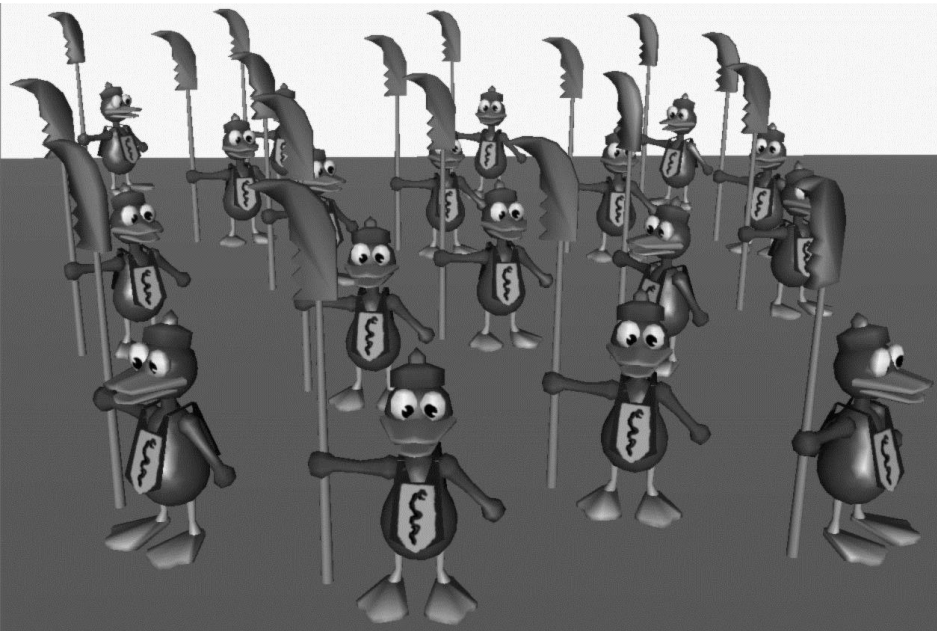

- Fog is atmospheric effect
 - Better realism, helps determine distances



Fog

- Fog was part of OpenGL fixed function pipeline
- Programming fixed function fog
 - **Parameters:** Choose fog color, fog model
 - **Enable:** Turn it on
- Fixed function fog **deprecated!!**
- Shaders can implement even better fog
- **Shaders implementation:** fog applied in fragment shader just before display



Rendering Fog

- Mix some color of fog: \mathbf{c}_f + color of surface: \mathbf{c}_s

$$\mathbf{c}_p = f\mathbf{c}_f + (1-f)\mathbf{c}_s \quad f \in [0,1]$$

- If $f = 0.25$, output color = 25% fog + 75% surface color

- f computed as function of distance z
- 3 ways: linear, exponential, exponential-squared
- Linear:

$$f = \frac{z_{end} - z_p}{z_{end} - z_{start}}$$

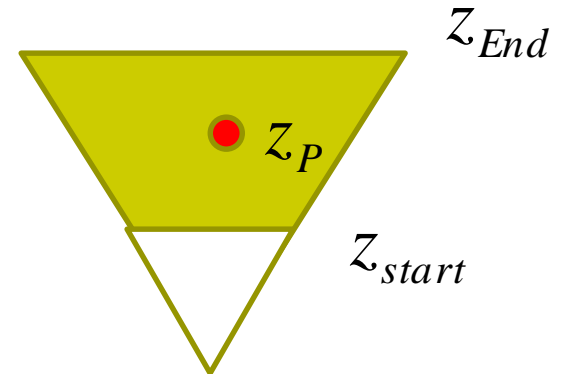

Fog Shader Fragment Shader Example



$$f = \frac{z_{end} - z_p}{z_{end} - z_{start}}$$

```
float dist = abs(Position.z);
```

```
Float fogFactor = (Fog.maxDist - dist) /  
                  Fog.maxDist - Fog.minDist);
```

```
fogFactor = clamp(fogFactor, 0.0, 1.0);
```

```
vec3 shadeColor = ambient + diffuse + specular
```

```
vec3 color = mix(Fog.color, shadeColor, fogFactor);
```

```
FragColor = vec4(color, 1.0);
```

$$\mathbf{c}_p = f\mathbf{c}_f + (1-f)\mathbf{c}_s$$



Fog

- Exponential $f = e^{-d_f z_p}$
- Squared exponential $f = e^{-(d_f z_p)^2}$
- Exponential derived from Beer's law
 - **Beer's law:** intensity of outgoing light diminishes exponentially with distance, similar to real life

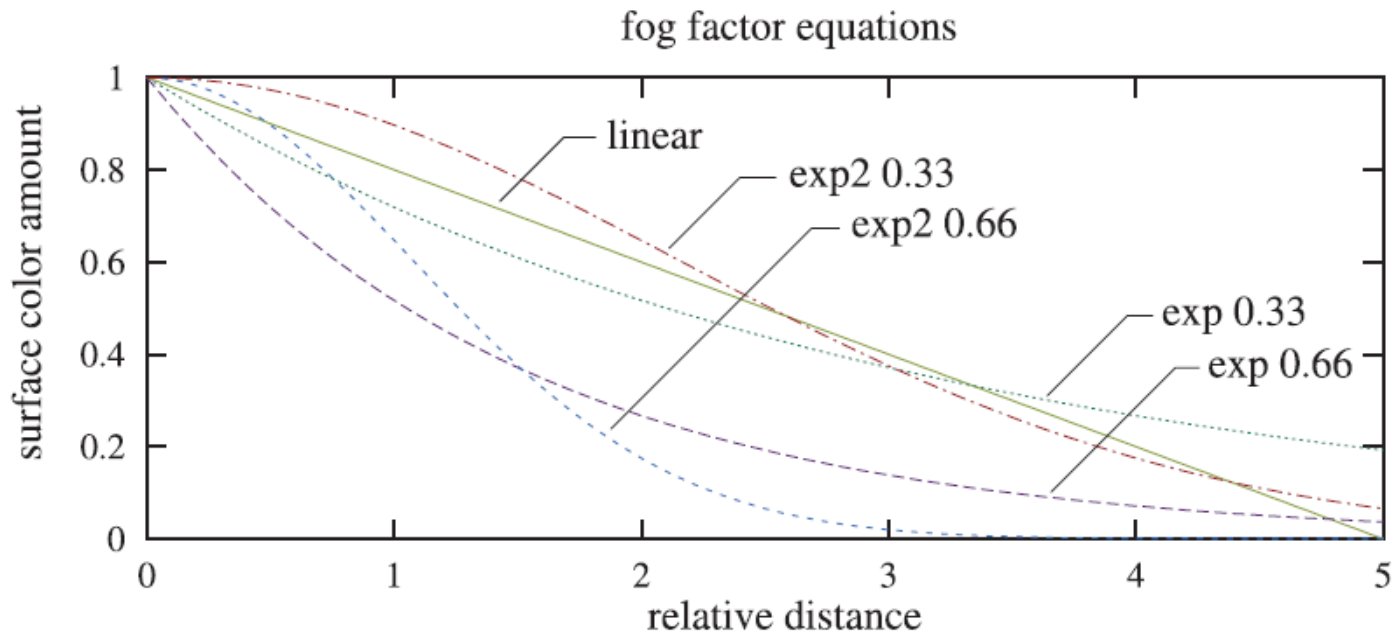



Fog Optimizations

- f values for different depths (z_P) can be pre-computed and stored in a table on GPU
- Distances used in f calculations are planar
- Can also use Euclidean distance from viewer or radial distance to create *radial fog*

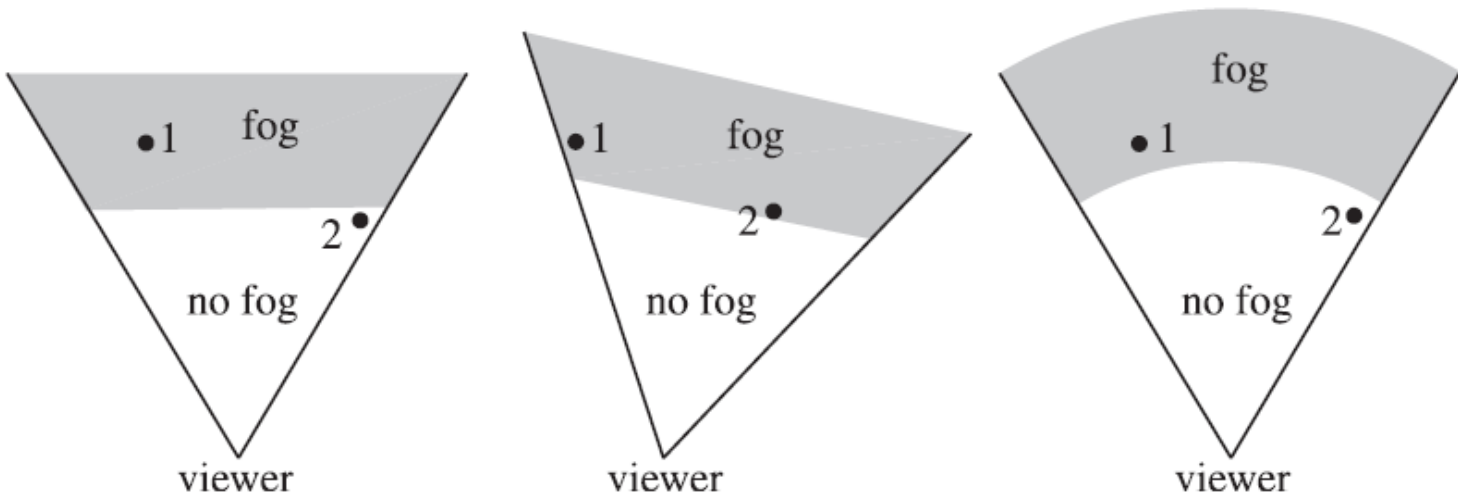



References

- Interactive Computer Graphics (6th edition), Angel and Shreiner
- Computer Graphics using OpenGL (3rd edition), Hill and Kelley
- Real Time Rendering by Akenine-Moller, Haines and Hoffman