

Computer Graphics (CS 543)

Lecture 5: Viewing & Camera Control

Prof Emmanuel Agu

*Computer Science Dept.
Worcester Polytechnic Institute (WPI)*





3D Viewing?

- Specify a view volume
- Objects **inside** view volume drawn to viewport (screen)
- Objects outside view volume **clipped** (not drawn)!

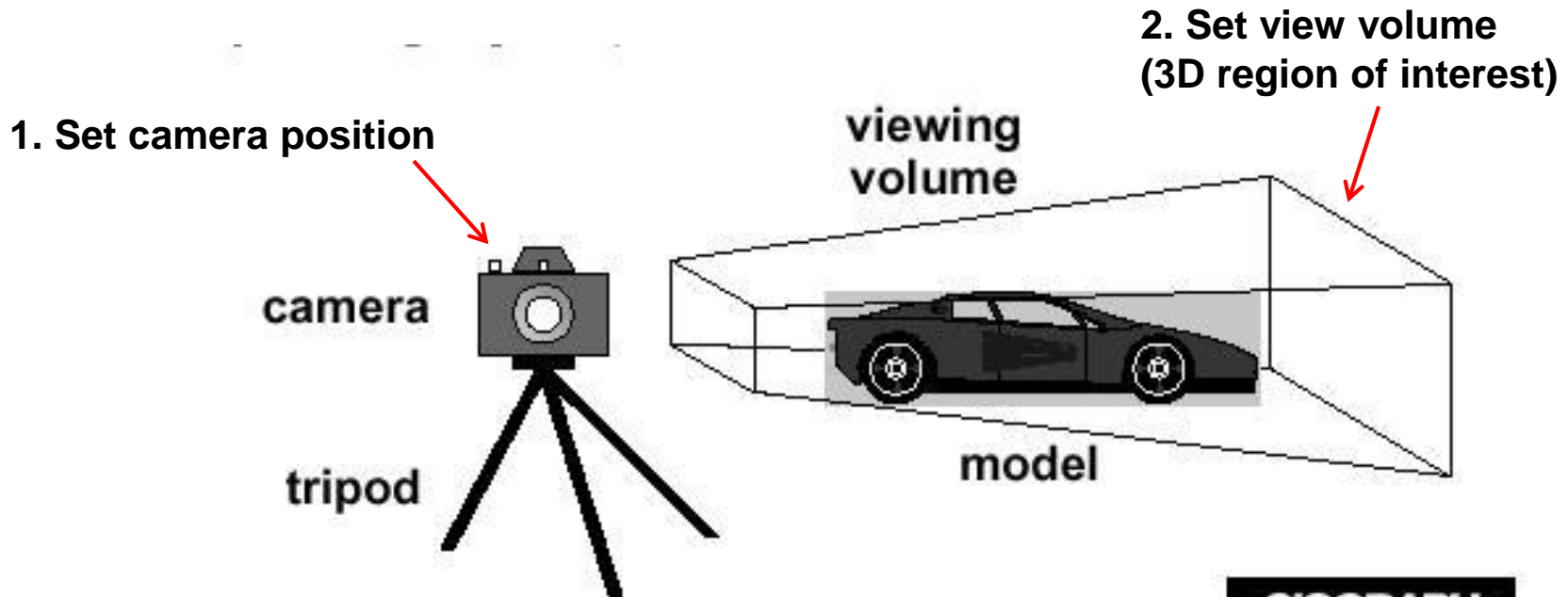

Different View Volume Shapes

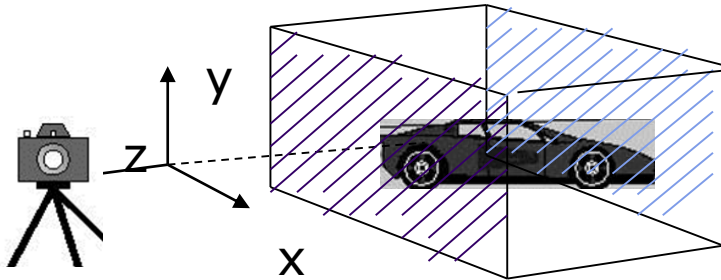

Orthogonal view volume

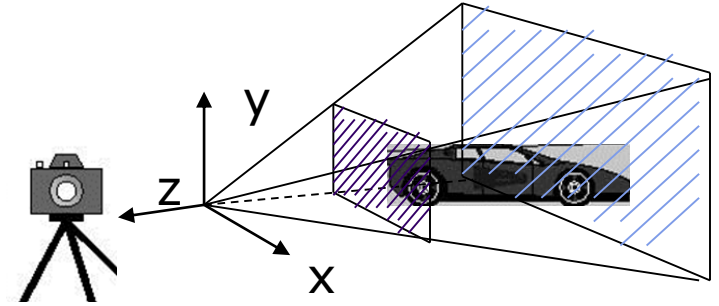

Perspective view volume

- Different view volume shape => different look
- **Foreshortening?** Near objects bigger
 - Perspective projection has **foreshortening**
 - Orthogonal projection: no foreshortening





The World Frame

- Object positions initially defined in **world frame**
- **World Frame origin** at $(0,0,0)$
- Objects positioned, oriented (translate, scale, rotate transformations) applied to objects in **world frame**

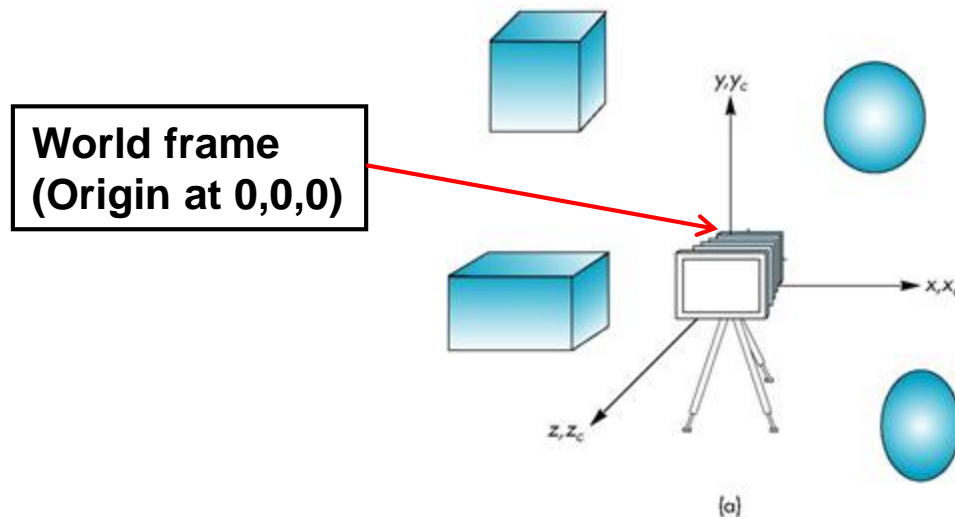



Camera Frame

- More natural to describe object positions **relative to camera (eye)**
- Why?
 - Our view of the world
 - First person shooter games



Camera Frame



- **Viewing:** After user chooses camera (eye) position, represent objects in **camera frame** (origin at eye position)
- **Viewing transformation:** Converts object (x,y,z) positions in world frame to positions in camera frame

Objects initially Specified in world frame

World frame
(Origin at 0,0,0)

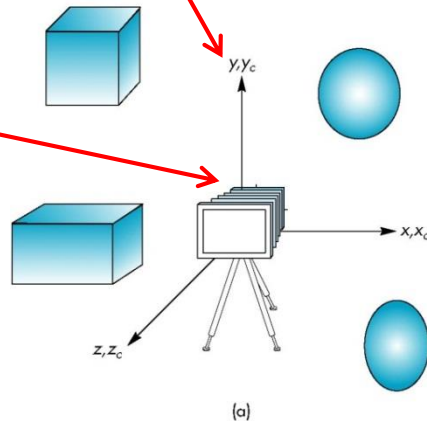

More natural to view
Objects in camera frame

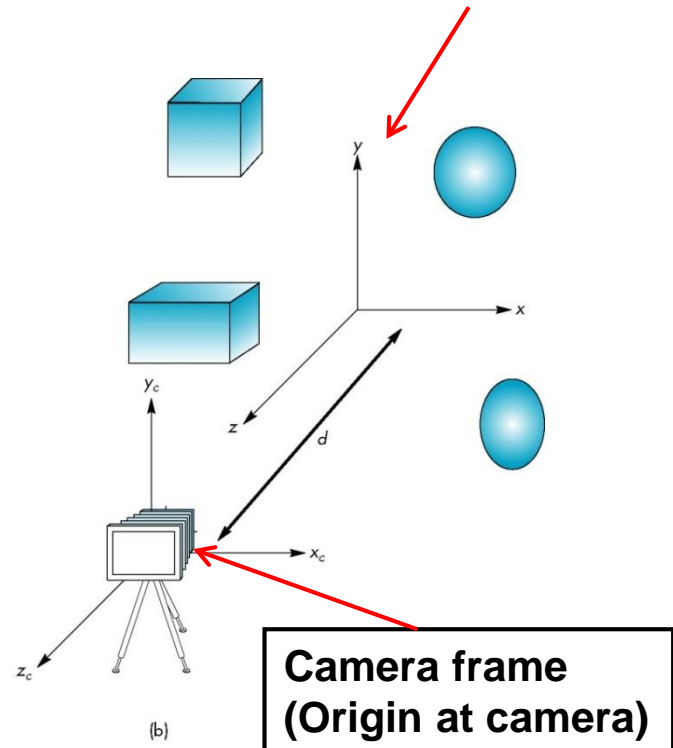

Camera frame
(Origin at camera)



Default OpenGL Camera

- Initially Camera at origin: object and camera frames same
- Points in negative z direction
- Default view volume is cube with sides of length 2

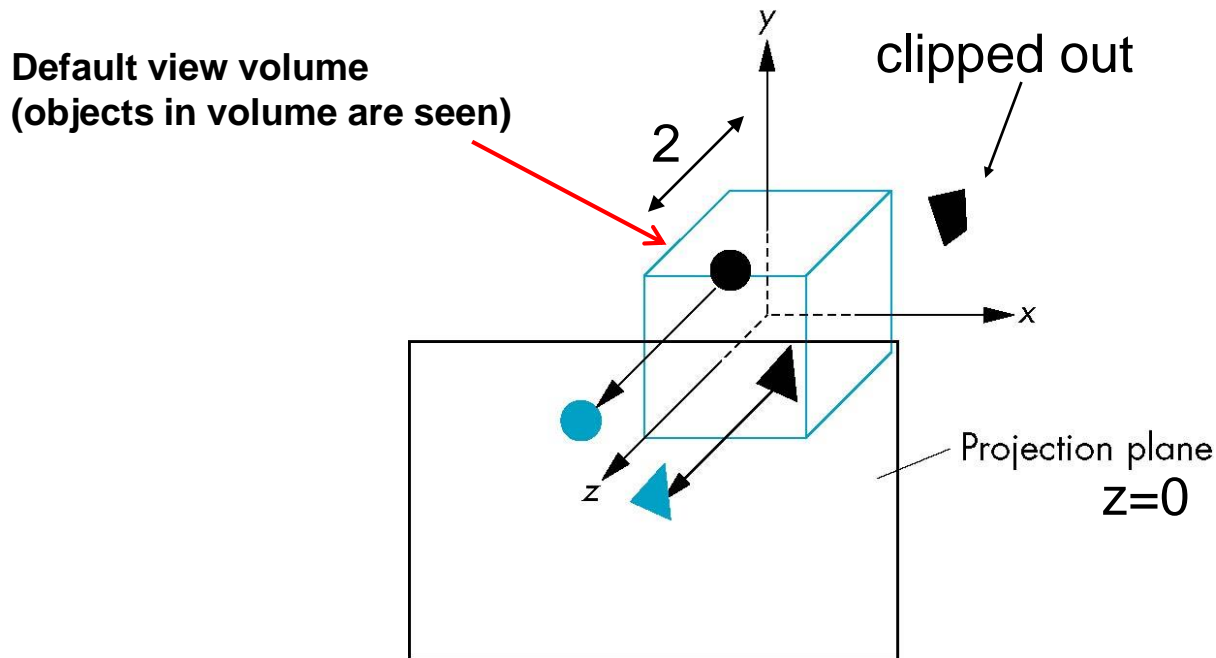

Moving Camera Frame



Same relative distance after
Same result/look

default frames

Translate **objects -5**
away from camera

Translate **camera +5**
away from objects

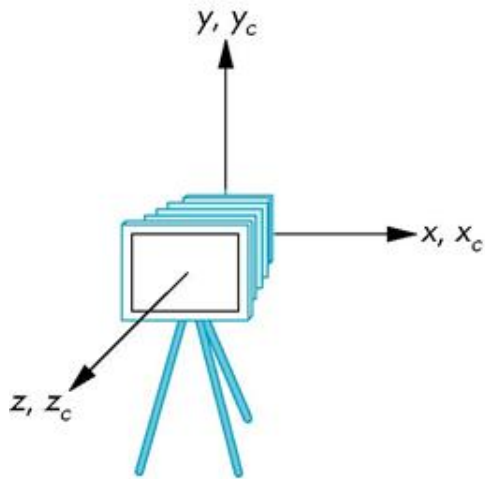

(a)

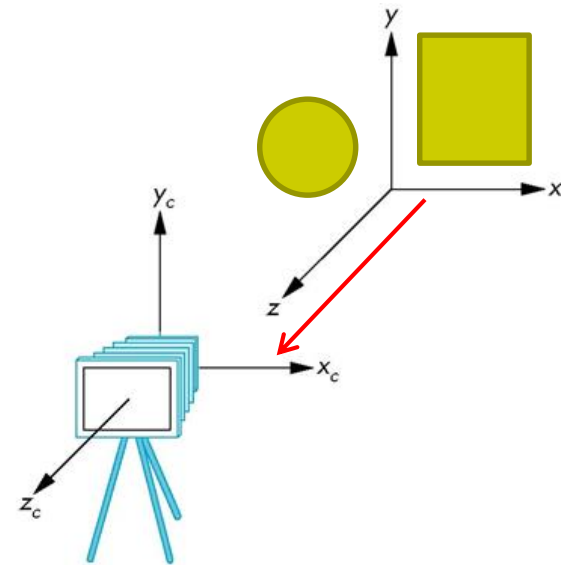
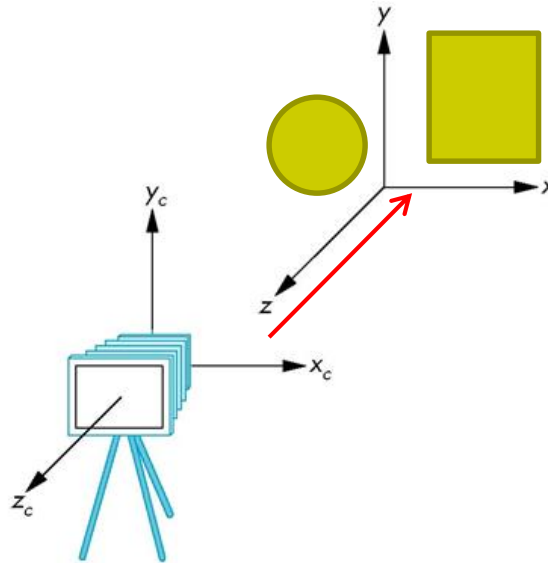



Moving the Camera

- We can move camera using sequence of rotations and translations
- Example: side view
 - Rotate the camera
 - Move it away from origin
 - Model-view matrix $C = TR$

```
// Using mat.h
```

```
mat4 t = Translate (0.0, 0.0, -d);  
mat4 ry = RotateY(90.0);  
mat4 m = t*ry;
```

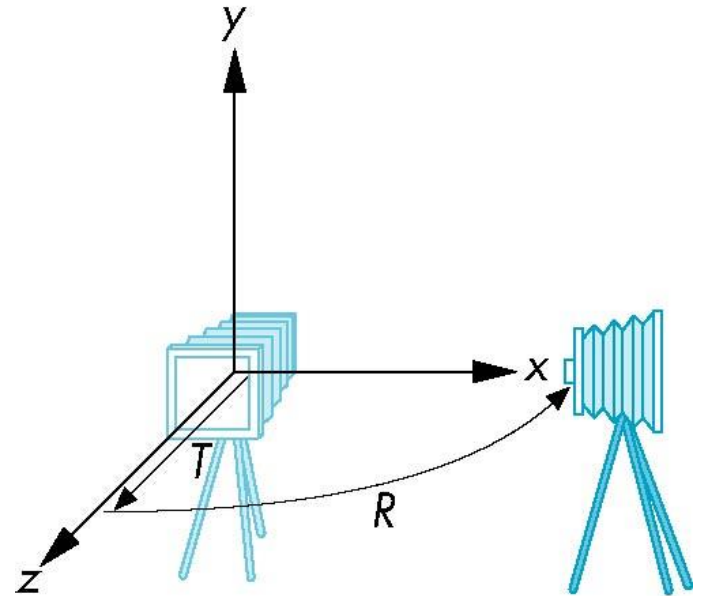



Moving the Camera Frame

- Object distances **relative to camera** determined by the model-view matrix
 - Transforms (scale, translate, rotate) go into **modelview matrix**
 - Camera transforms also go in **modelview matrix (CTM)**

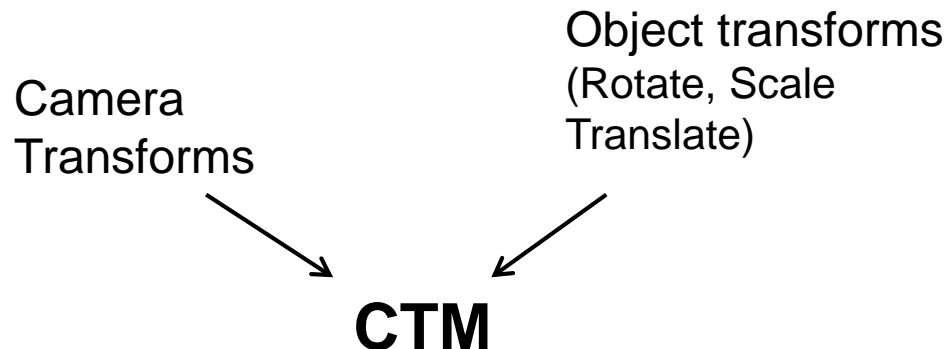



The LookAt Function

- Previously, command **gluLookAt** to position camera
- **gluLookAt** deprecated!!
- Homegrown mat4 method LookAt() in mat.h
 - Sets camera position, transforms object distances to camera frame

```
void display( ) {  
    .....  
  
    mat4 mv = LookAt(vec4 eye, vec4 at, vec4 up);  
    .....  
}
```

Builds 4x4 matrix for positioning, orienting Camera and puts it into variable **mv**



The LookAt Function

LookAt(*eye*, *at*, *up*)

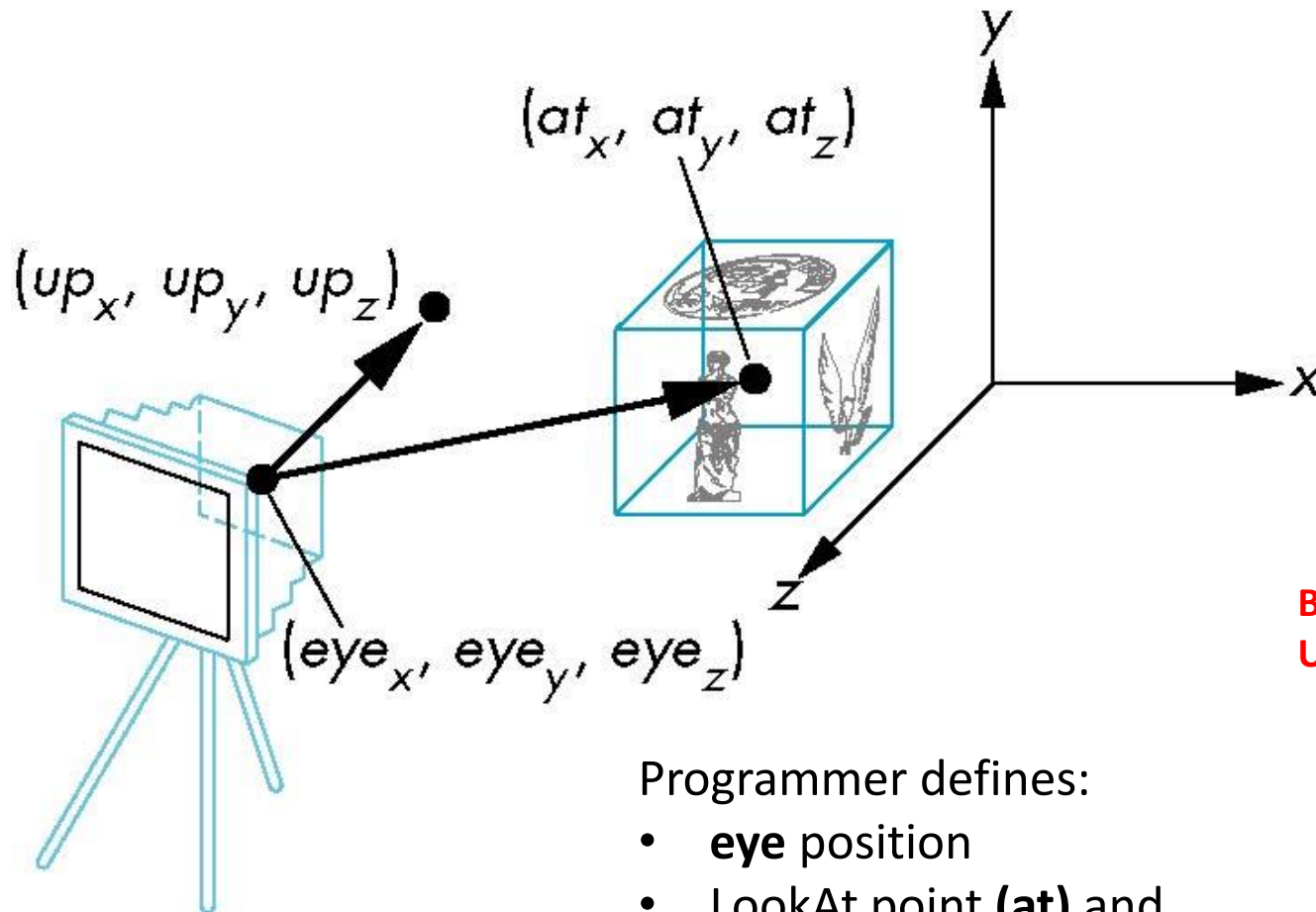

But Why do we set
Up direction?

Programmer defines:

- **eye** position
- LookAt point (**at**) and
- **Up** vector (**Up** direction usually (0,1,0))

Nate Robbins LookAt Demo



World-space view

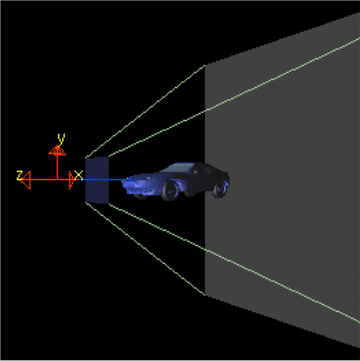

Screen-space view



Command manipulation window

```
glTranslatef( 0.00 , 0.00 , 0.00 );  
glRotatef( 0.0 , 0.00 , 1.00 , 0.00 );  
glScalef( 1.00 , 1.00 , 1.00 );  
glBegin( ... );  
...  
Click on the arguments and move the mouse to modify values.
```

World-space view

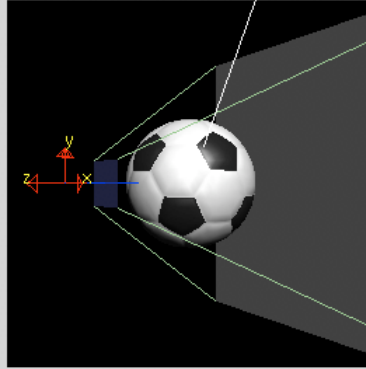

Screen-space view



Command manipulation window

```
GLfloat pos[4] = { 1.50 , 1.00 , 1.00 , 0.00 };  
gluLookAt( 0.00 , 0.00 , 2.00 , <- eye  
          0.00 , 0.00 , 0.00 , <- center  
          0.00 , 1.00 , 0.00 ); <- up  
glLightfv(GL_LIGHT0, GL_POSITION, pos);  
Click on the arguments and move the mouse to modify values.
```

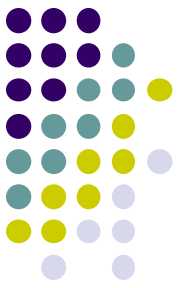

What does LookAt do?

- Programmer defines eye, lookAt and Up
- **LookAt method:**
 - Forms new axes (u, v, n) at camera
 - Transform objects from world to eye camera frame

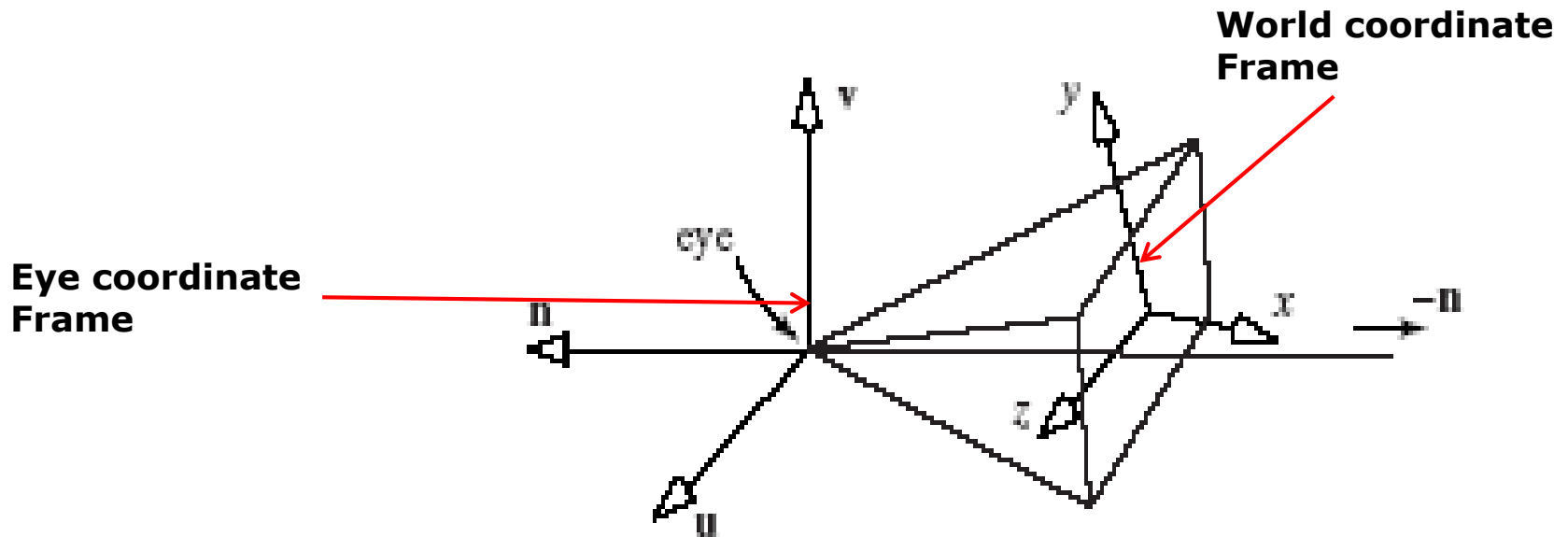

Camera with Arbitrary Orientation and Position

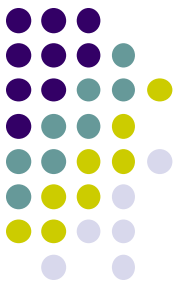

- Define new axes (u, v, n) at eye
 - v points vertically upward,
 - n away from the view volume,
 - u at right angles to both n and v .
 - The camera looks toward $-n$.
 - All vectors are normalized.

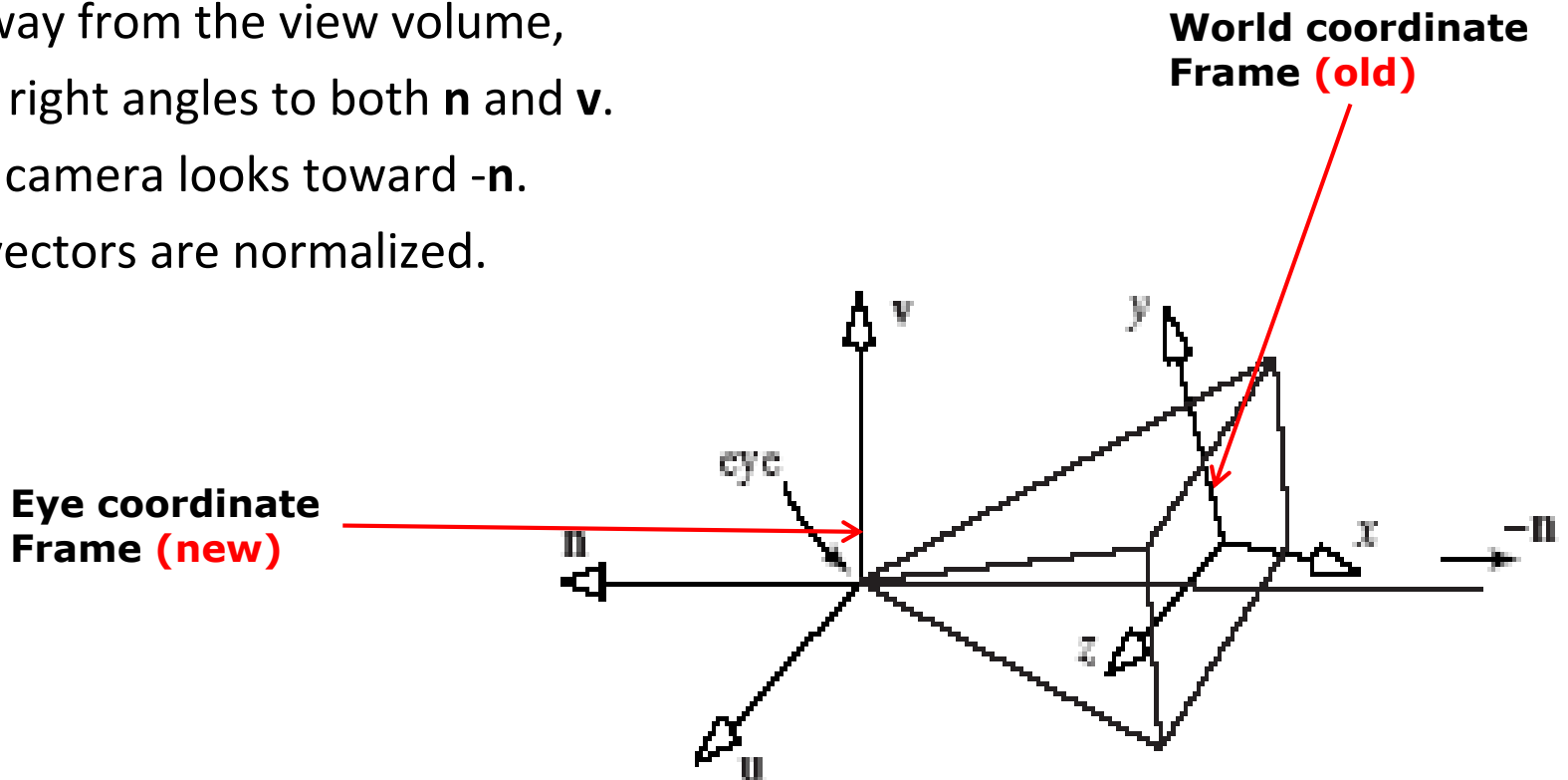



LookAt: Effect of Changing Eye Position or LookAt Point

- Programmer sets **LookAt** (**eye**, **at**, **up**)
- If **eye**, **lookAt** point changes => **u,v,n** changes

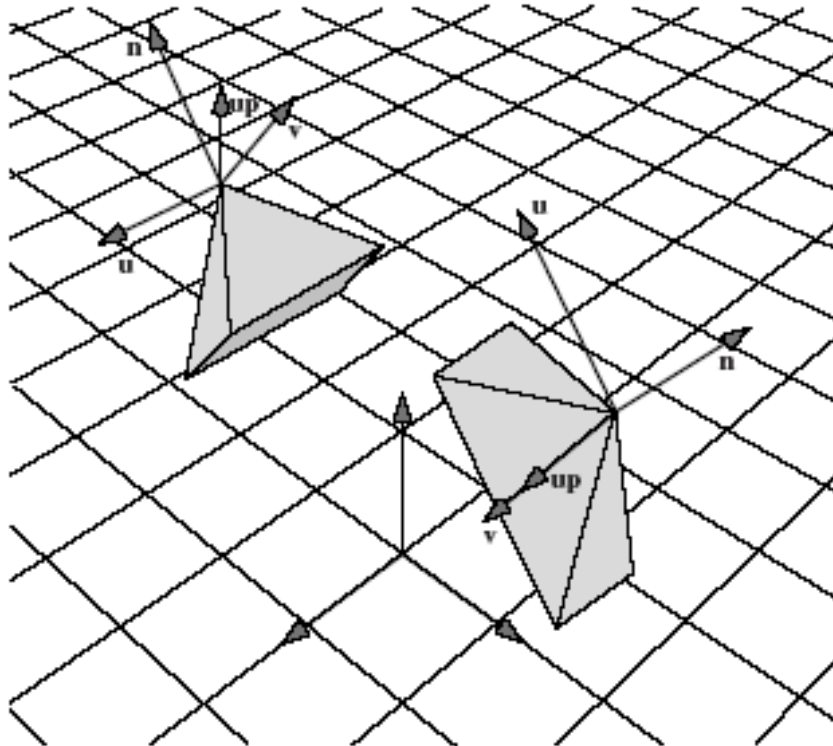



Viewing Transformation Steps

1. Form camera (u,v,n) frame
 2. Transform objects from world frame (Composes matrix to transform coordinates)
- Next, let's form camera (u,v,n) frame

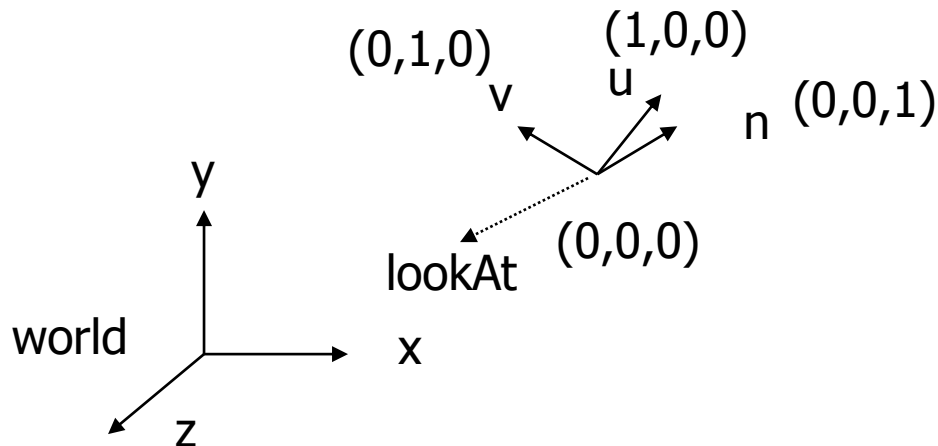



Constructing U,V,N Camera Frame

- Lookat arguments: **LookAt** (**eye**, **at**, **up**)
- **Known:** eye position, LookAt Point, up vector
- **Derive:** new origin and three basis (u,v,n) vectors

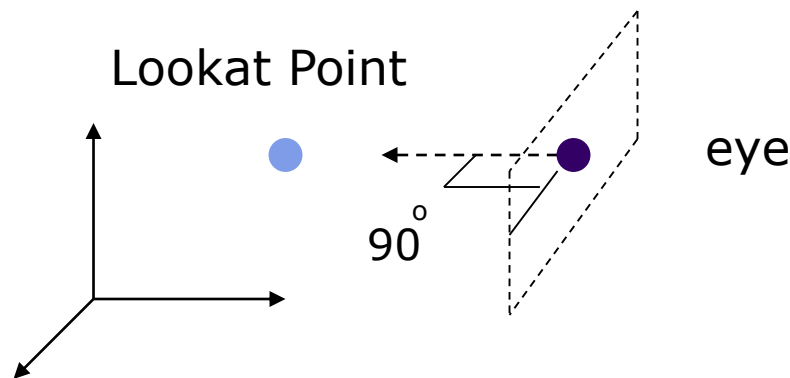



Eye Coordinate Frame

- **New Origin:** eye position (that was easy)
- 3 basis vectors:
 - one is the normal vector (**n**) of the viewing plane,
 - other two (**u** and **v**) span the viewing plane

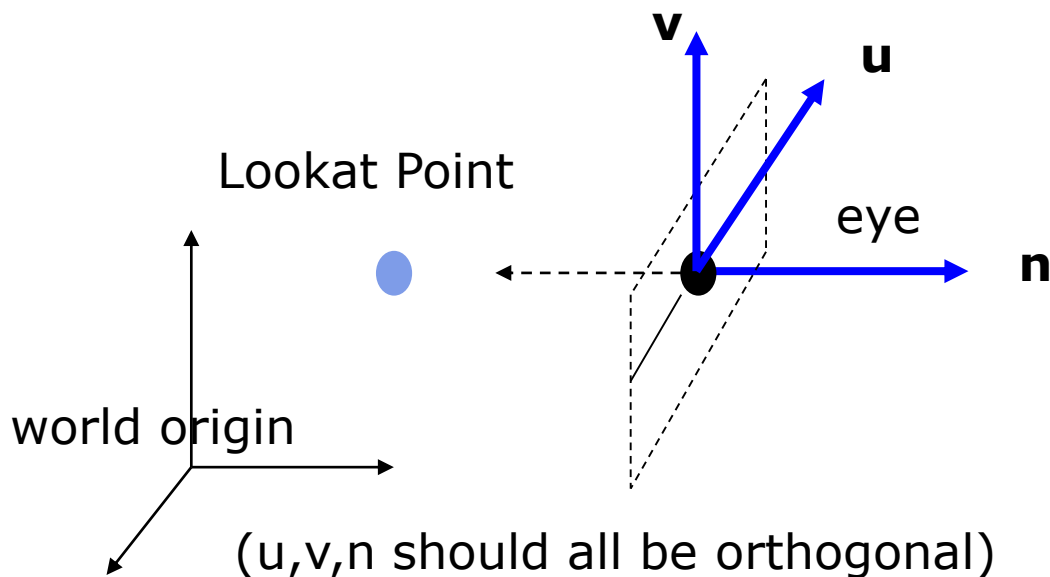

n is pointing away from the world because we use left hand coordinate system

$$\mathbf{N} = \text{eye} - \text{Lookat Point}$$
$$\mathbf{n} = \mathbf{N} / |\mathbf{N}|$$

Remember **u,v,n** should be all unit vectors
So... Normalize vectors!!!!



Eye Coordinate Frame

- How about u and v ?

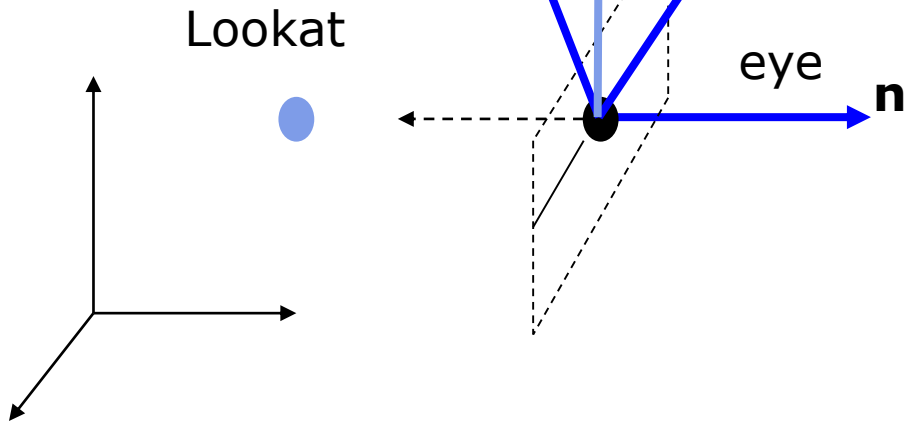

- Derive u first -
 - u is a vector that is perp to the plane spanned by N and view up vector (V_up)

$$U = V_up \times n$$

$$u = U / |U|$$



Eye Coordinate Frame

- How about v ?

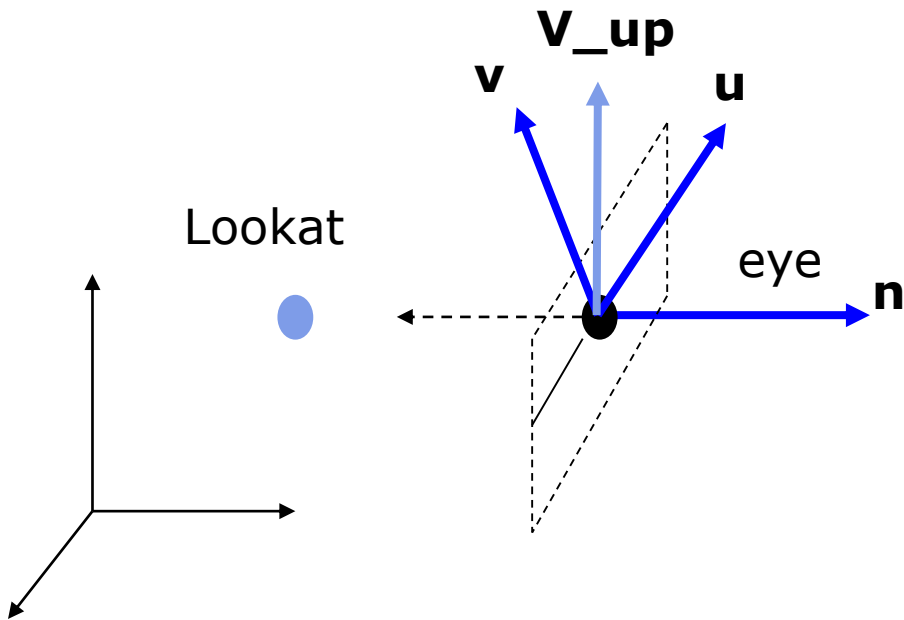

To derive v from n and u

$$\mathbf{v} = \mathbf{n} \times \mathbf{u}$$

v is already normalized



Eye Coordinate Frame

- Put it all together

Eye space **origin: (Eye.x , Eye.y, Eye.z)**

Basis vectors:

$$\mathbf{n} = (\text{eye} - \text{Lookat}) / |\text{eye} - \text{Lookat}|$$

$$\mathbf{u} = (\mathbf{V_up} \times \mathbf{n}) / |\mathbf{V_up} \times \mathbf{n}|$$

$$\mathbf{v} = \mathbf{n} \times \mathbf{u}$$

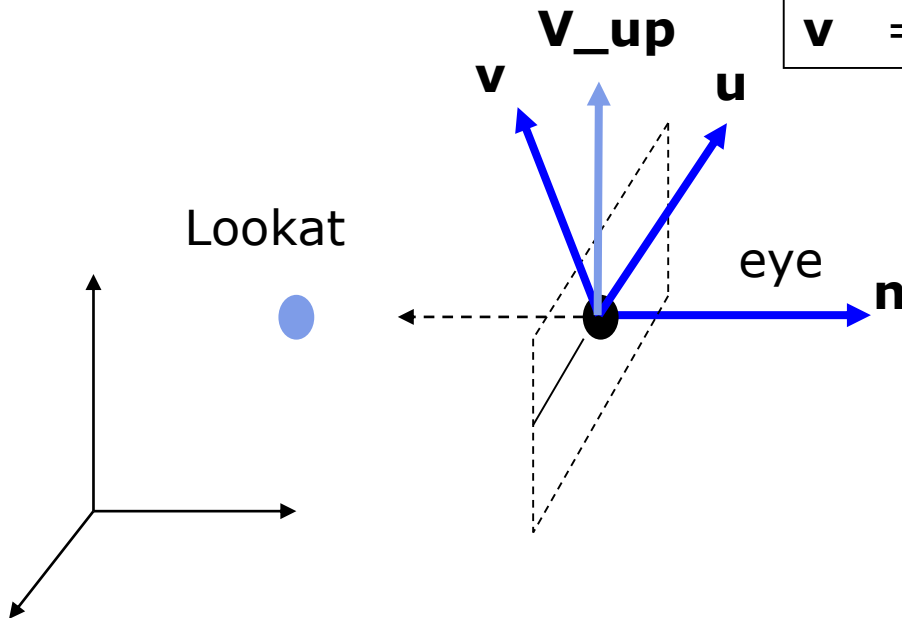



Step 2: World to Eye Transformation

- Next, use u, v, n to compose LookAt matrix
- Transformation matrix (M_{w2e}) ?
 - Matrix that transforms a point P in world frame to P' in eye frame

$$P' = M_{w2e} P$$

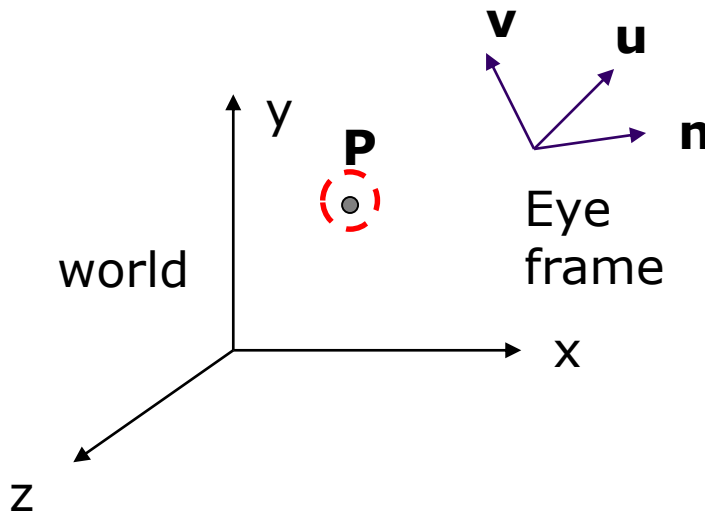

1. Come up with transformation sequence that lines up eye frame with world frame

2. Apply this transform sequence to point P in reverse order



World to Eye Transformation

1. Rotate eye frame to “align” it with world frame
2. Translate $(-ex, -ey, -ez)$ to align origin with eye

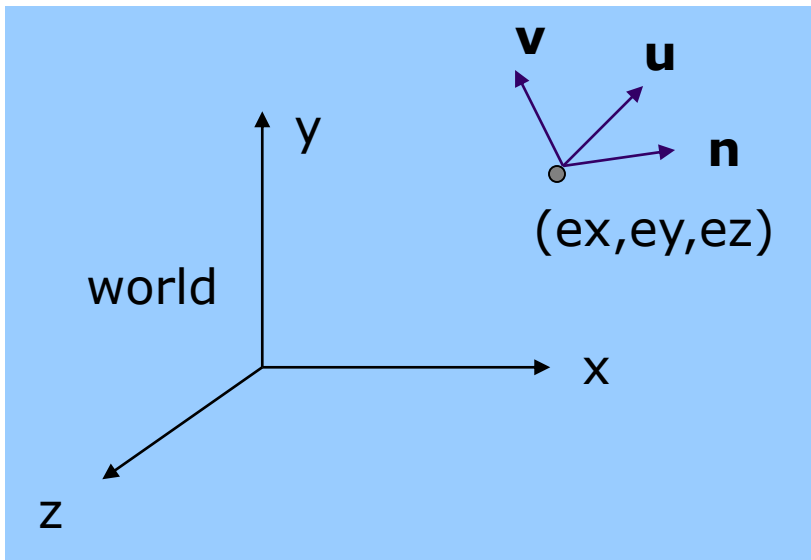

Rotation:

$$\begin{vmatrix} ux & uy & uz & 0 \\ vx & vy & vz & 0 \\ nx & ny & nz & 0 \\ 0 & 0 & 0 & 1 \end{vmatrix}$$

Translation:

$$\begin{vmatrix} 1 & 0 & 0 & -ex \\ 0 & 1 & 0 & -ey \\ 0 & 0 & 1 & -ez \\ 0 & 0 & 0 & 1 \end{vmatrix}$$

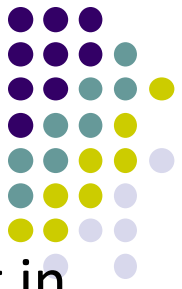

World to Eye Transformation

- Transformation order: apply the transformation to the object in reverse order - translation first, and then rotate

← Order

$M_{w2e} =$

Rotation	Translation
$\begin{vmatrix} u_x & u_y & u_z & 0 \\ v_x & v_y & v_z & 0 \\ n_x & n_y & n_z & 0 \\ 0 & 0 & 0 & 1 \end{vmatrix}$	$\begin{vmatrix} 1 & 0 & 0 & -e_x \\ 0 & 1 & 0 & -e_y \\ 0 & 0 & 1 & -e_z \\ 0 & 0 & 0 & 1 \end{vmatrix}$

$$= \begin{vmatrix} u_x & u_y & u_z & -\mathbf{e} \cdot \mathbf{u} \\ v_x & v_y & v_z & -\mathbf{e} \cdot \mathbf{v} \\ n_x & n_y & n_z & -\mathbf{e} \cdot \mathbf{n} \\ 0 & 0 & 0 & 1 \end{vmatrix}$$

Multiplied together = lookAt transform

Note: $\mathbf{e} \cdot \mathbf{u} = e_x \cdot u_x + e_y \cdot u_y + e_z \cdot u_z$

$\mathbf{e} \cdot \mathbf{v} = e_x \cdot v_x + e_y \cdot v_y + e_z \cdot v_z$

$\mathbf{e} \cdot \mathbf{n} = e_x \cdot n_x + e_y \cdot n_y + e_z \cdot n_z$

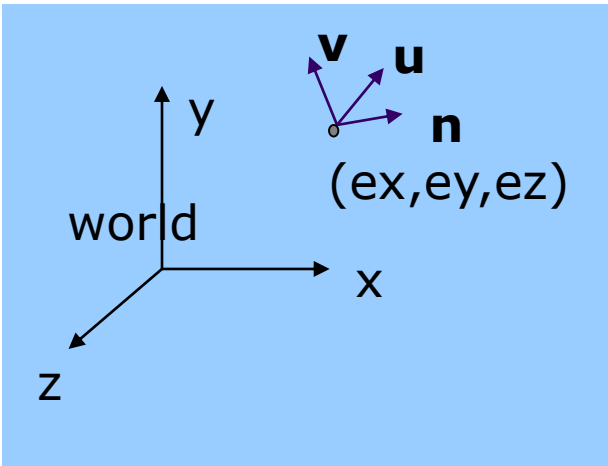



lookAt Implementation (from mat.h)

Eye space **origin: (Eye.x , Eye.y, Eye.z)**

Basis vectors:

$$\begin{aligned}\mathbf{n} &= (\text{eye} - \text{Lookat}) / |\text{eye} - \text{Lookat}| \\ \mathbf{u} &= (\mathbf{V_up} \times \mathbf{n}) / |\mathbf{V_up} \times \mathbf{n}| \\ \mathbf{v} &= \mathbf{n} \times \mathbf{u}\end{aligned}$$

$$\begin{vmatrix} u_x & u_y & u_z & -\mathbf{e} \cdot \mathbf{u} \\ v_x & v_y & v_z & -\mathbf{e} \cdot \mathbf{v} \\ n_x & n_y & n_z & -\mathbf{e} \cdot \mathbf{n} \\ 0 & 0 & 0 & 1 \end{vmatrix}$$

```
mat4 LookAt( const vec4& eye, const vec4& at, const vec4& up )
{
    vec4 n = normalize(eye - at);
    vec4 u = normalize(cross(up, n));
    vec4 v = normalize(cross(n, u));
    vec4 t = vec4(0.0, 0.0, 0.0, 1.0);
    mat4 c = mat4(u, v, n, t);
    return c * Translate( -eye );
}
```



References

- Interactive Computer Graphics, Angel and Shreiner, Chapter 4
- Computer Graphics using OpenGL (3rd edition), Hill and Kelley