



---

# IMGD 5100: Immersive HCI

## Introduction

**Robert W. Lindeman**

Associate Professor

Interactive Media & Game Development

Department of Computer Science

Worcester Polytechnic Institute

[gogo@wpi.edu](mailto:gogo@wpi.edu)

---

# Course Goals

---

- ❑ Learn about designing, building, and evaluating immersive interfaces
- ❑ Look at how humans function
- ❑ Look at application areas
- ❑ Look at usage environments
- ❑ Understand the main problems/sub-fields
- ❑ Build something cool!

# Assignments

---

- 2-3 Assignments
  - Each uses different technologies
- Paper summaries
  - You will write short summaries for several papers
- Final Project
  - Done in groups of two
  - Go deeper into one application/technology
  - Evaluate your system with a user study

# Final project

---

- Choose
  - User population
  - Application
  - Usage environment (e.g., mobile)
- Choose I/O devices/techniques
- Design the application
- Design the interface & interaction
- Build the system
- Assess the result

# Assignments

---

- Can be done in teams
  - Clearly define what each member will be responsible for
- Can use any software/language you like
- Samples
  - OpenGL, DirectX, Java3D, OpenSceneGraph, OpenSG, FreeVR, Android, iphone
  - Game-engine code
- Resources
  - HIVE has many devices for you to use.
  - Field trip later in the semester
  - Android phones

# What is Virtual Reality?

---

□ You tell me!

# Virtual Reality Systems

---

- 1929 - Link Flight Simulator
- 1946 - First computer (ENIAC)
- 1956 - Sensorama
- 1960 - Heileg's HMD
- 1965-68 - The Ultimate Display
- 1972 - Pong
- 1973 - Evans & Sutherland Computer Corp.
- 1976 - Videoplace
- 1977 - Apple, Commodore, and Radio Shack PCs
- 1979 - First Data Glove [Sayre] (powerglove -89)
- 1981 - SGI founded
- 1985 - NASA AMES
- 1986-89 - Super Cockpit Program
- 1990s - Boom Displays
- 1992 - CAVE (at SIGGRAPH)
- 1995 - Workbench
- 1998 - Walking Experiment

# Link Flight Simulator

- ❑ 1929 - Edward Link develops a *mechanical flight simulator*
- ❑ Train in a synthetic environment
- ❑ Used mechanical linkages
- ❑ Instrument (blind) flying
  
- ❑ [http://www.wpafb.af.mil/museum/early\\_years/ey19a.htm](http://www.wpafb.af.mil/museum/early_years/ey19a.htm)

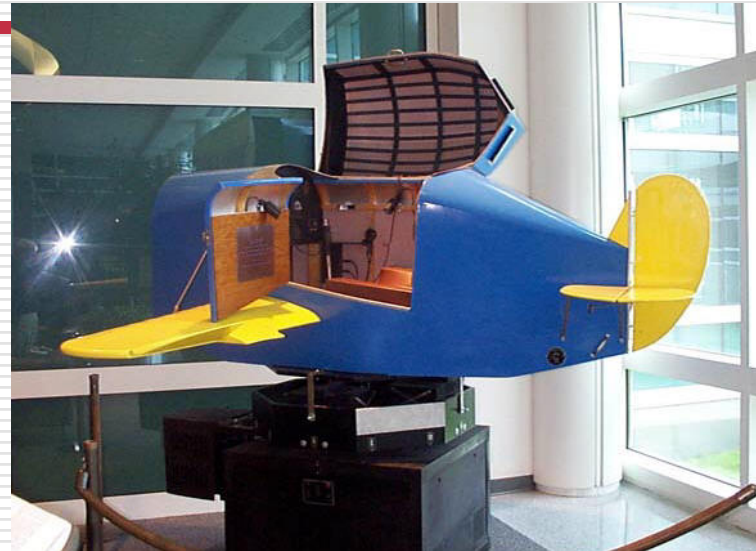

Instrument panel of the Link on display  
The Link trainer was donated by Simulation Products Division, The Singer Co., Binghamton, NY.



# Sensorama

---

## **Morton Heilig, 1956**

**Motorcycle simulator - all senses**

- **visual (city scenes)**
- **sound (engine, city sounds)**
- **vibration (engine)**
- **smell (exhaust, food)**

Extend the notion of a 'movie'



# Heilig's HMD (1960)

*Simulation Mask from Heilig's 1960 patent*

- ❑ 3D photographic slides
- ❑ WFOV optics with focus control
- ❑ Stereo sound
- ❑ Smell

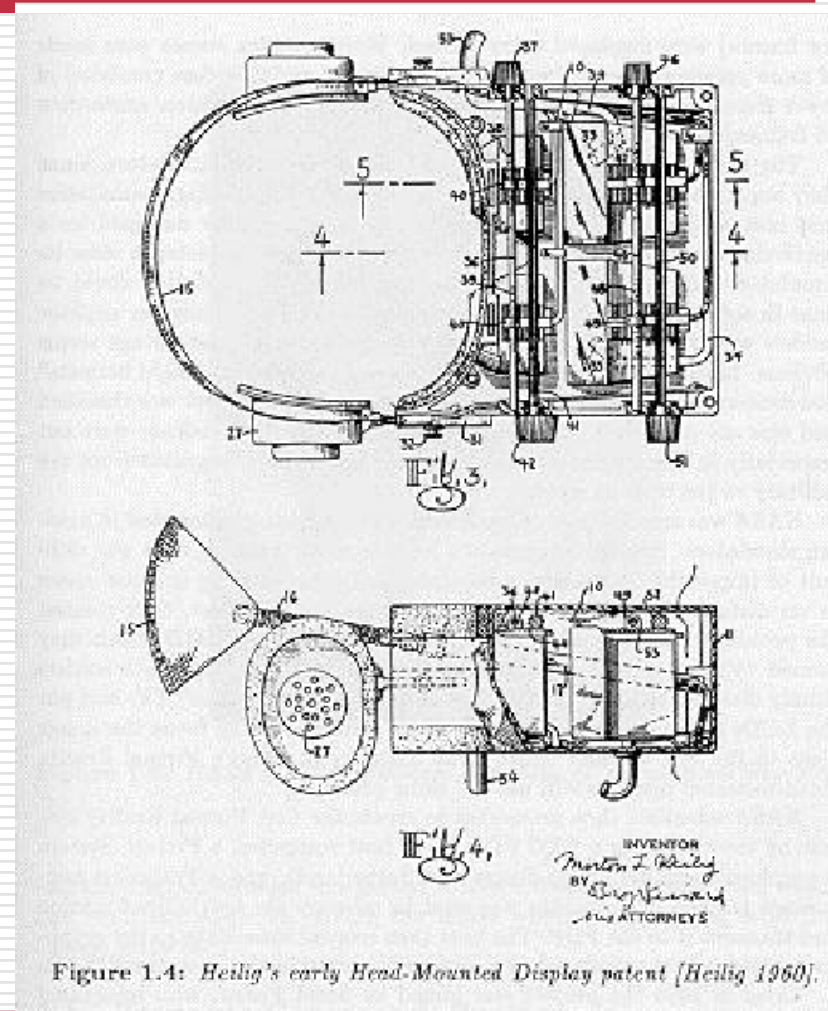

Figure 1.4: Heilig's early Head-Mounted Display patent [Heilig 1960].

# Ivan Sutherland

---

- The Ultimate Display (FIPS 1965)
  - Data Visualization: “A display connected to a digital computer...is a looking glass into a mathematical wonderland.”
  - Body Tracking: “The computer can easily sense the positions of almost any of our body muscles.”

# Ultimate Display (cont.)

---

- Virtual Environments that mimic real environments: “A chair displayed in such a room would be good enough to sit in. Handcuffs displayed in such a room would be confining, and a bullet displayed in such a room would be fatal.”
- VEs that go beyond reality: “There is no reason why the objects displayed by a computer have to follow ordinary rules of physical reality with which we are familiar.”

# First HMD-Based VR

---



1965 - The Ultimate Display  
paper by Sutherland

1968 - Ian Sutherland's HMD

# Molecular Docking Simulator

---

- ❑ Incorporated force feedback
- ❑ Visualize an abstract simulation

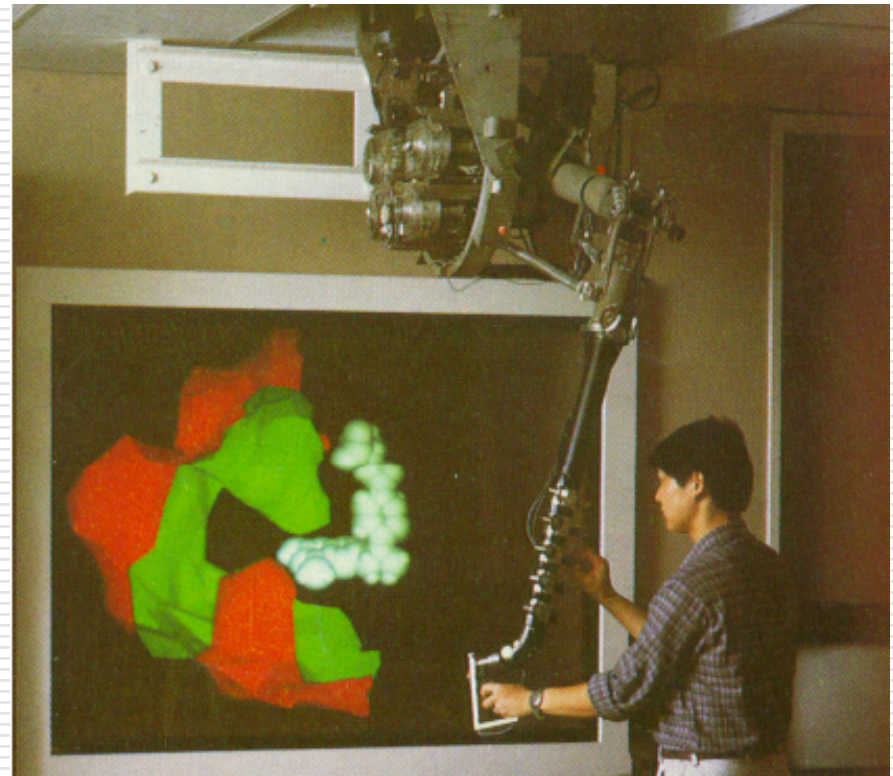

# Data Gloves

- Light, electrical or metal detectors compute “bend”
- Electrical sensors detect pinches
- Force feedback mechanical linkages

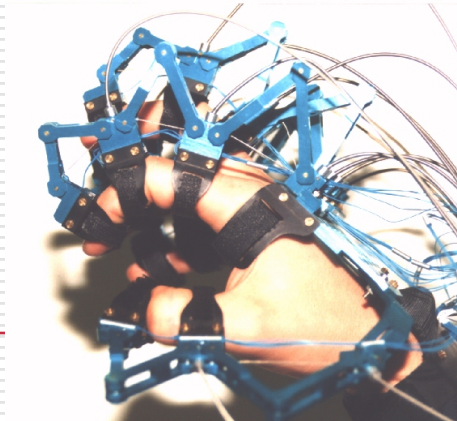

# 1985 - NASA Ames HMD

- McGreevy and and Humphries
  - Wearable immersive HMDs
  - LCD “Watchman” displays
  - LEEP Optics
- Led to VIVID, led by Scott Fisher





# FakeSpace Boom Display: Early 1990s

---

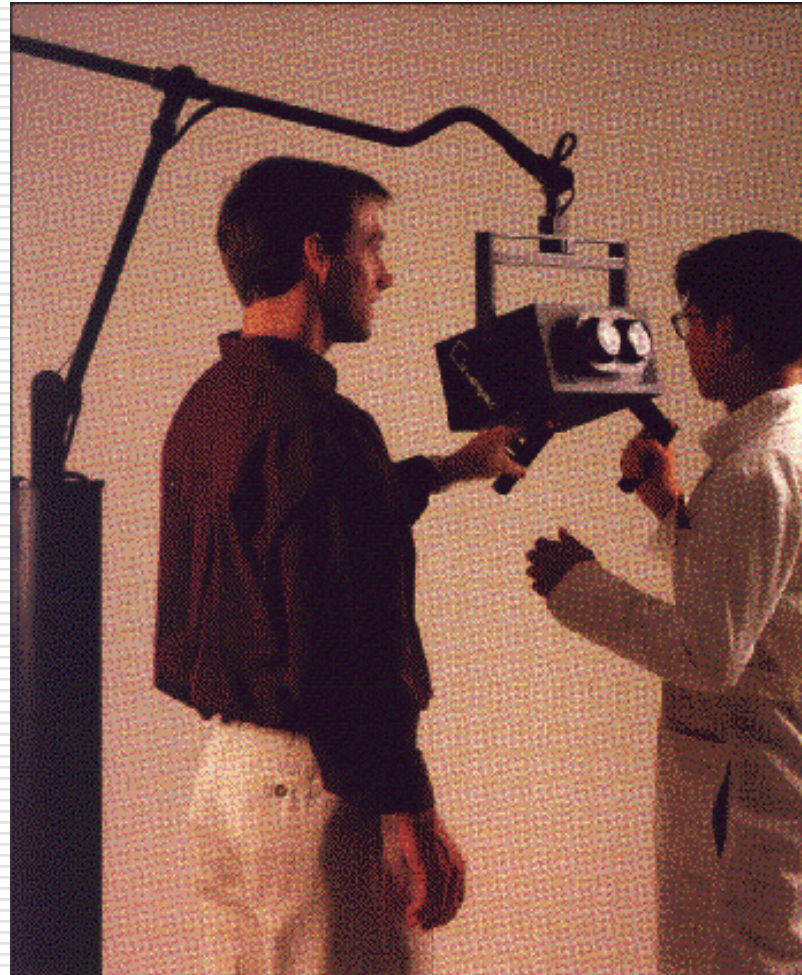

# CAVE - 1992

---

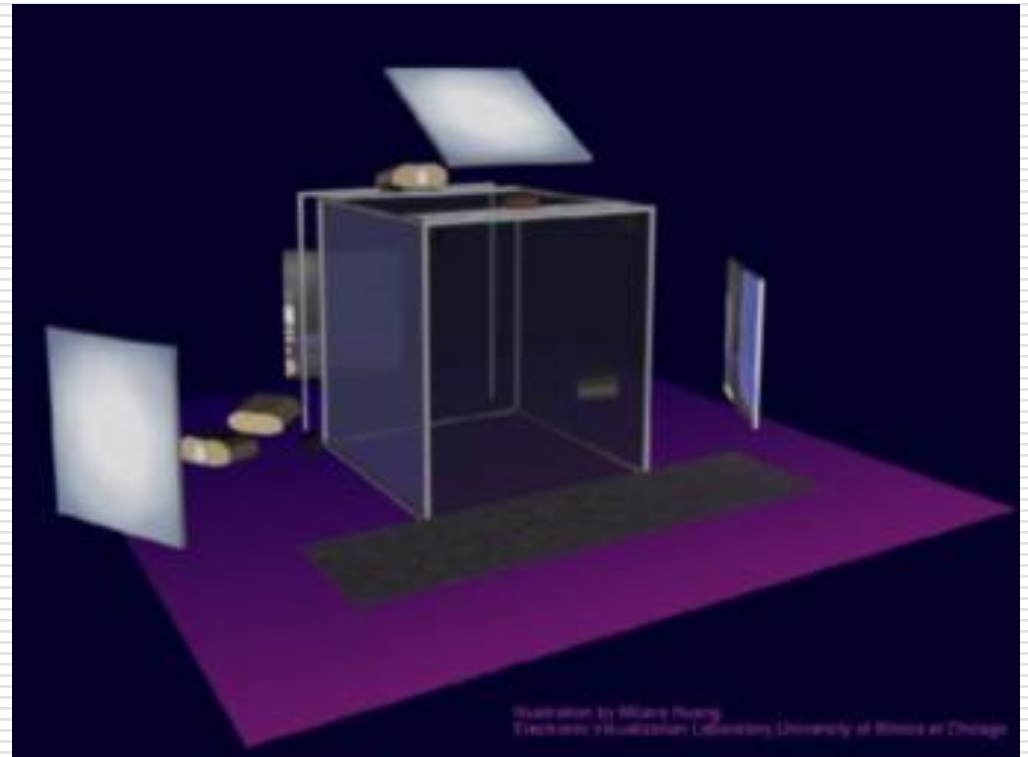
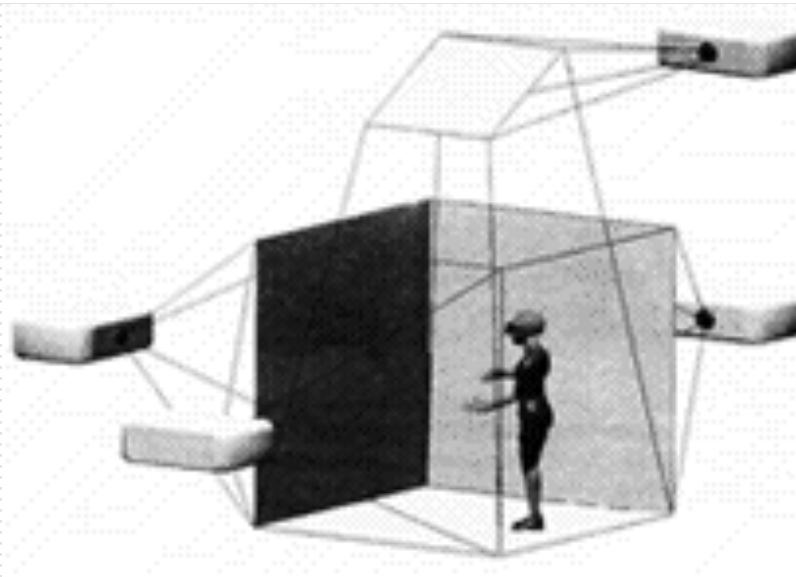

# Virtual Workbench-1995

(Responsive Workbench, Immersidesk, etc.)



# Current Best VE

- ❑ UNC Pit Experiment
- ❑ Fear of Heights a Strong Response
- ❑ Thousands of visitors
- ❑ Compelling Experience
  - Haptics
  - Low Latency
  - High Visual Quality

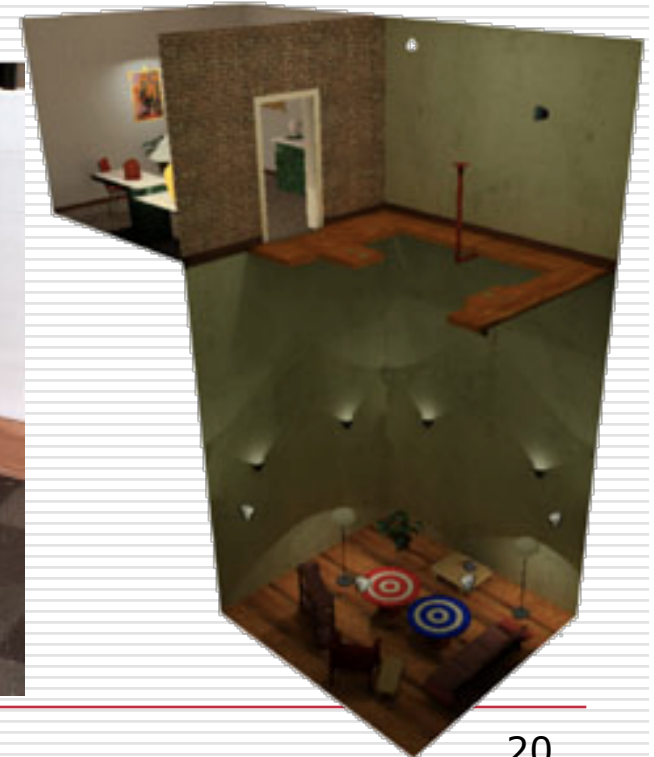

## VPL Founded - 1985

---

- First VR Company
- VPL Research by Jaron Lanier and Thomas Zimmerman
  - Data Glove
  - Term: Virtual Reality



1995 - Effectiveness of computer-generated (VR) graded exposure  
in the treatment of acrophobia in *American Journal of Psychiatry*

---

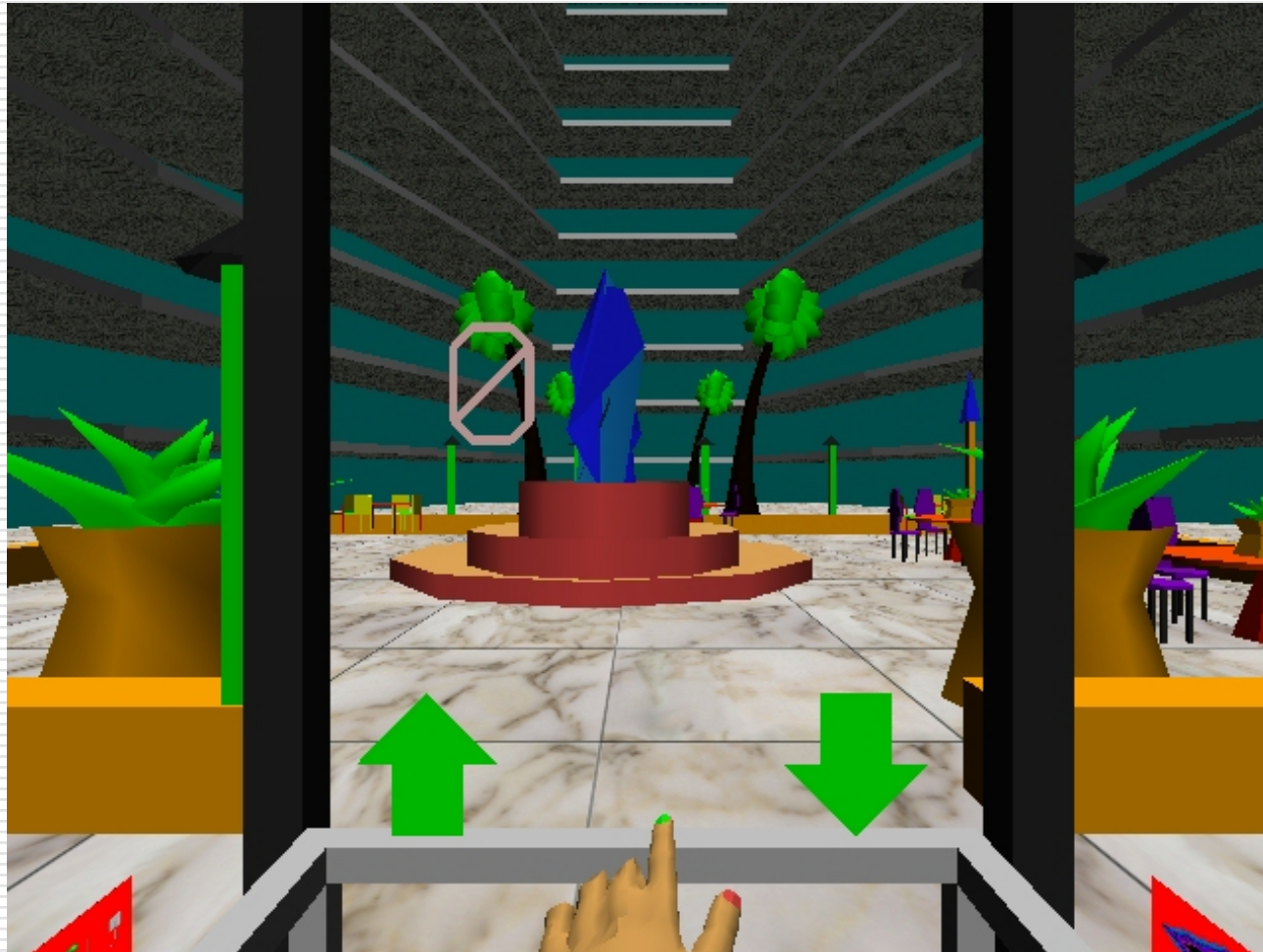

# Major Reinvigoration: Hardware Evolution

---

- High expense
- PC performance surpasses Graphics supercomputers
  - SGI RealityEngine (300k tris – 1993)
  - XBOX (150 mil tri/sec - 2001)
  - XBOX360 (500 mil tri/sec - 2005)
  - WiiMote/MotionPlus
  - Sony MOVE (SHOW MOVIE!)
  - MS Kinect (SHOW MOVIE!)
- Large LCDs are “cheap”
- 3D displays are here
  - Useful?

# Why Study Immersive HCI?

---

- Relevant to real-world tasks
  - Can use familiarity to ease adaptation
  - Can increase realism of experience
  
- Mature technology
  - Cheap, robust solutions
  - Need to create interface mappings
  
- 3D interaction is difficult
  - Many VR/gaming systems lack necessary cues
  - Adapting WIMP techniques is not adequate



# Why Study Immersive HCI? (cont.)

---

- Current approaches are either too simple or unusable
  - Since users have problems, dumb it down!
  - Need to be able to perform all actions though!
  
- Ripe area for study
  - Very hot area of HCI
  - We know *a lot* about doing things in 2D
  - And also about doing things in the real world
  - Mobile wearable systems emerging

# A Brief History (cont.)

---

- HCI draws on
  - Perception
  - Cognition
  - Linguistics
  - Human factors
  - Ethnography
  - Graphic design
  - Computer science
  - ...

## A Brief History (cont.)

---

- Technology developments also drove growth
  - Flight simulators
  - 3D Graphics
  - Augmented Reality (AR)
  - Virtual Reality (VR)
  - Flight

# Basic Interaction Tasks in VR (Bowman *et al.*)

---



- Object Selection
  - What do I want to manipulate?
- Object Manipulation
  - How can I manipulate it?
- Navigation
  - Wayfinding: How do I know where I am, and how to get where I am going?
  - Travel: How do I get there? (locomotion)
- System Control
  - How do I change system parameters?
- Symbolic Input
  - Inputting text and numbers

## *World Builder* (Bruce Banit)

---

- ❑ Concept film
- ❑ Can you spot the different tasks?

# Dealing with Objects

- Problems
  - Ambiguity
  - Distance
- Selection Approaches
  - Direct / enhanced grabbing
  - Ray-casting techniques
  - Image-plane techniques
- Manipulation Approaches
  - Direct position / orientation control
  - Worlds in miniature
  - Skewers
  - Surrogates

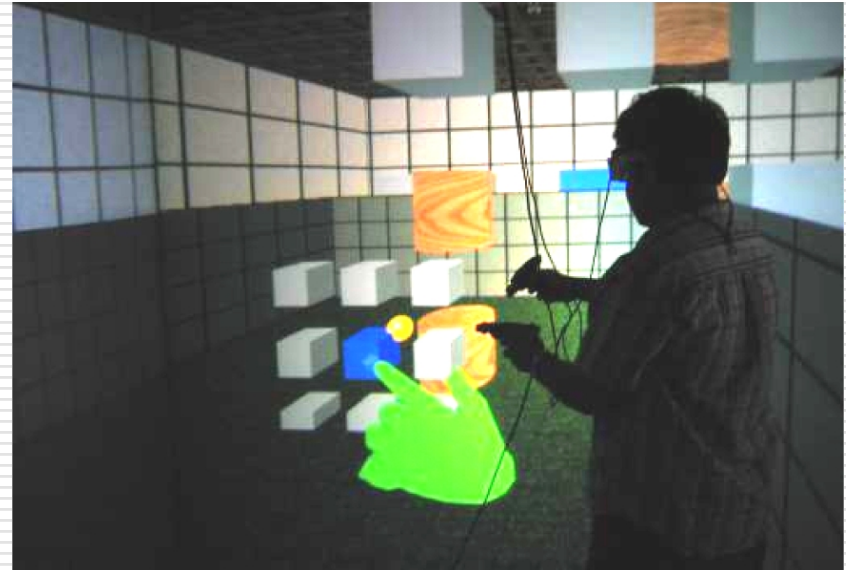

Courtesy: D. Bowman

# Navigation: Wayfinding

- People get lost/disoriented easily
- Traditional tools
  - Maps (North-up vs. Forward-up)
  - Landmarks
  - Spoken directions
- Non-traditional
  - Callouts
  - Zooming

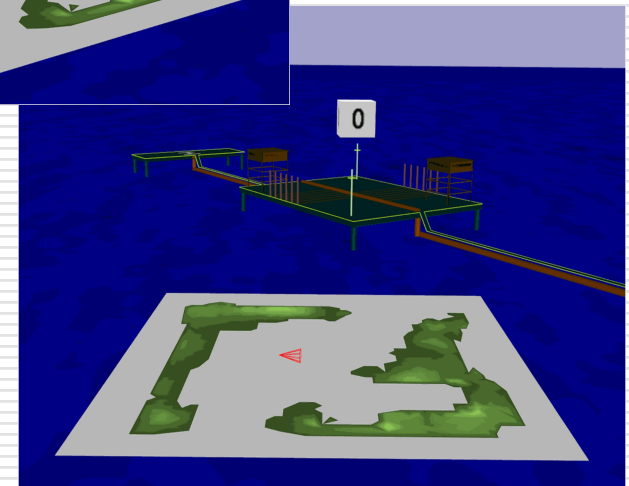
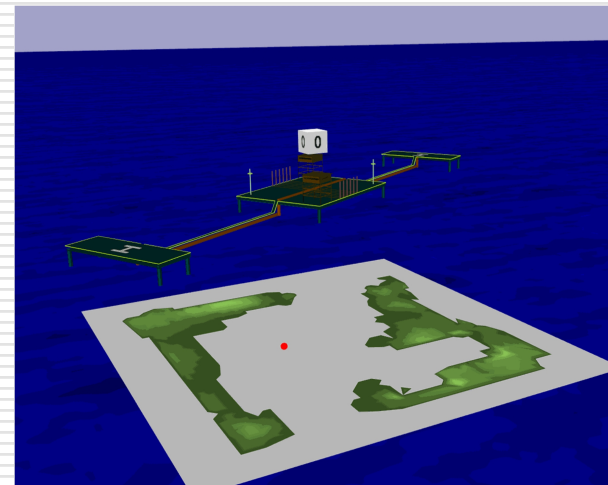

Images: <http://vehand.engr.ucf.edu/handbook/Chapters/Chapter28/Chapter28.html>

# Navigation: Travel

---

## □ Problems

- Limited physical space, unlimited virtual space
- Cables

## □ Approaches

- Fly where you point/look
- Treadmills
- Walking in place
- Big track ball

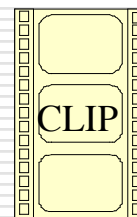

Image: [www.virtusphere.com](http://www.virtusphere.com)



# System Control

---

- Need to manipulate widgets
  - Lighting effects
  - Object representation
  - Data filtering
  
- Approaches
  - Floating windows
  - Hand-held windows
  - Gestures
  - Menus on fingers

# System Control Examples

Courtesy: R. Lindeman

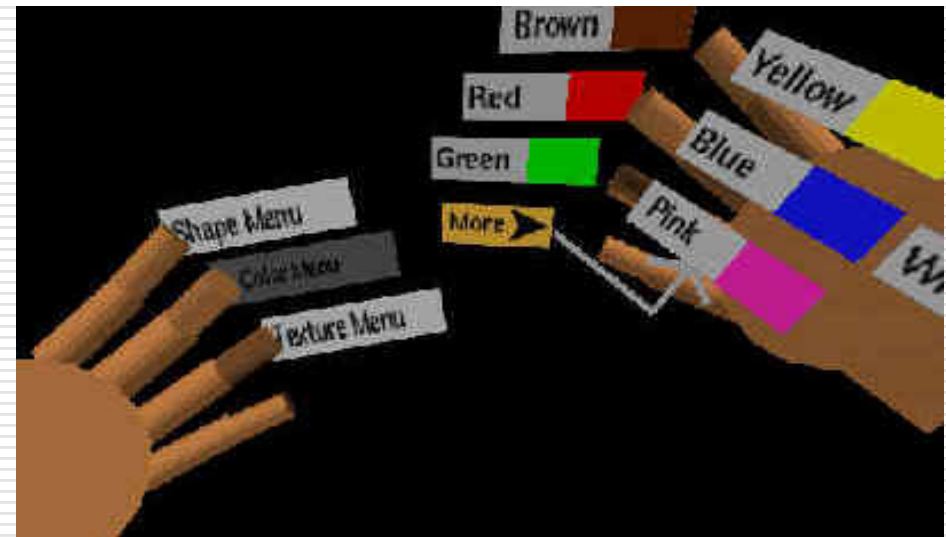
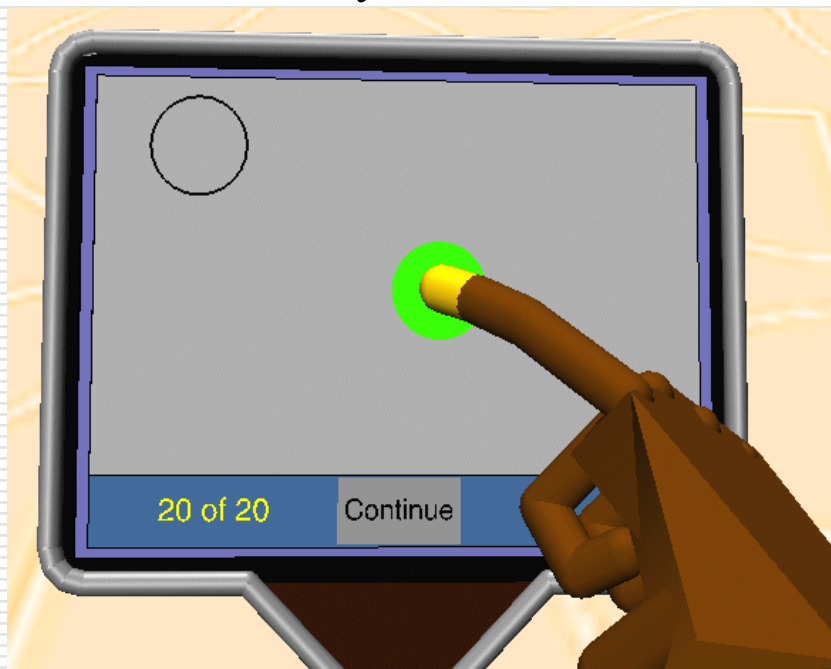

Courtesy: D. Bowman

# User, Task & Environment

---

- The "optimal" interface will depend on the capabilities of the *user*, the nature of the *task* being performed, and the constraints of the *environment*.
- User
  - Dexterity, level of expertise
- Task
  - Granularity and complexity of task
- Environment
  - Stationary, moving, noisy, *etc.*

# Direct Manipulation

---

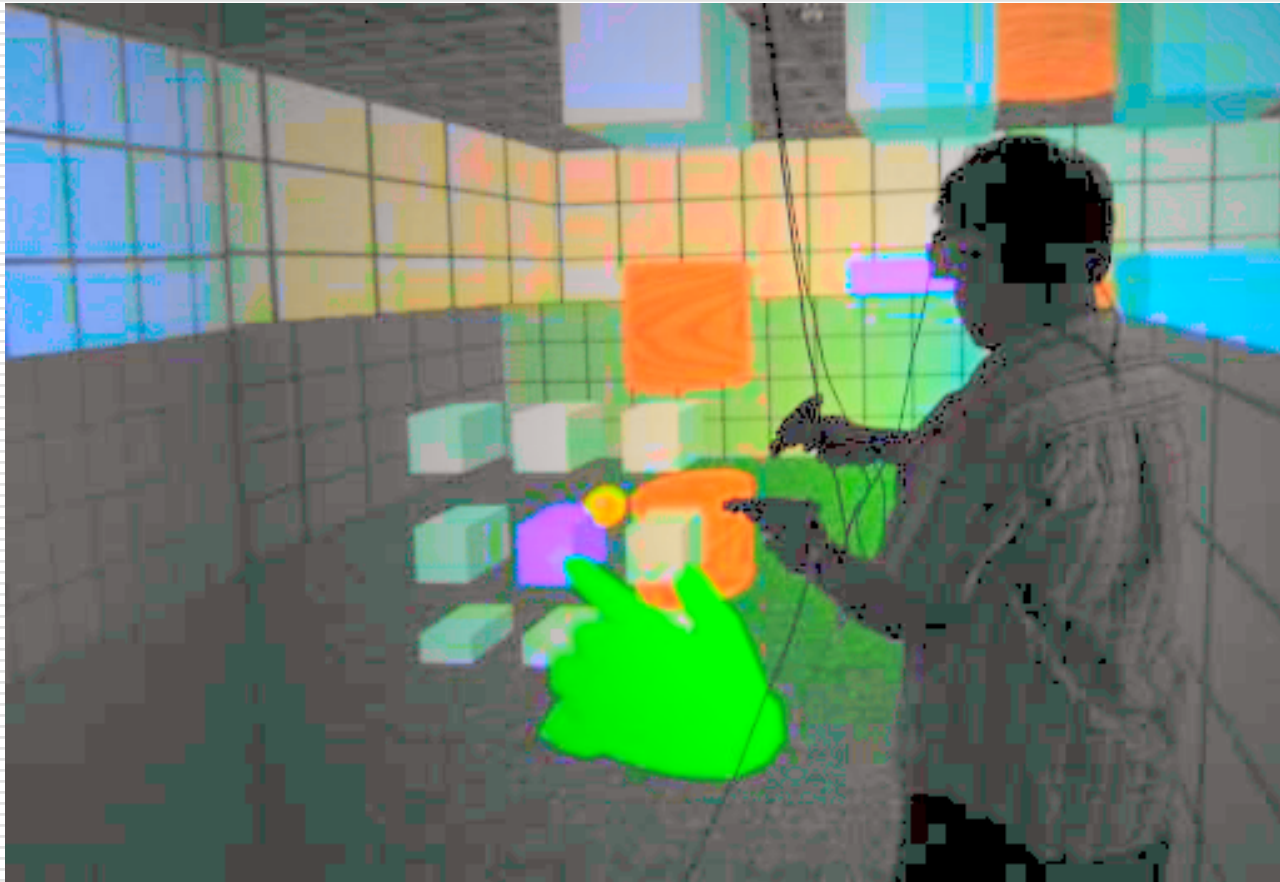

Copyright 2004, WPI

# Can We Do WIMP in VR?

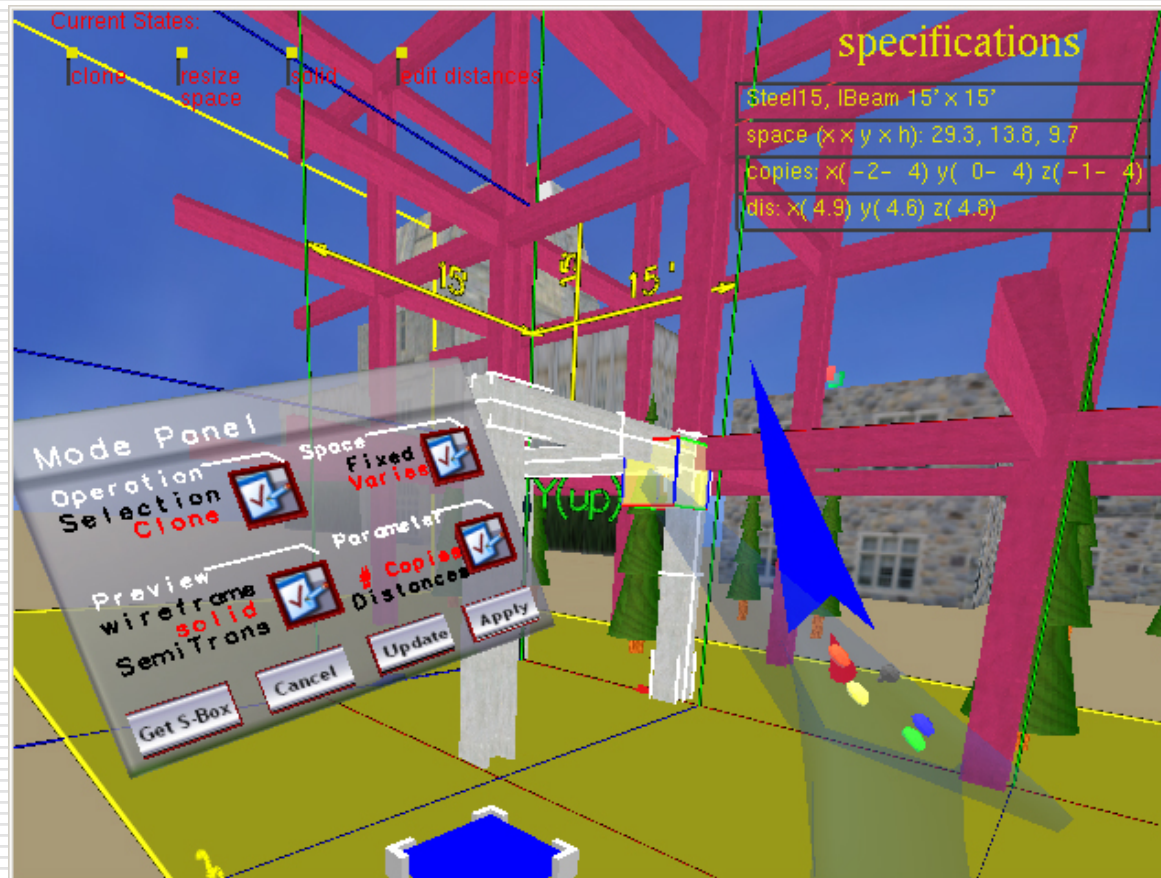

Continuing Virtual Reality

# Desktop Interaction: SensAble *PHANToM*

---

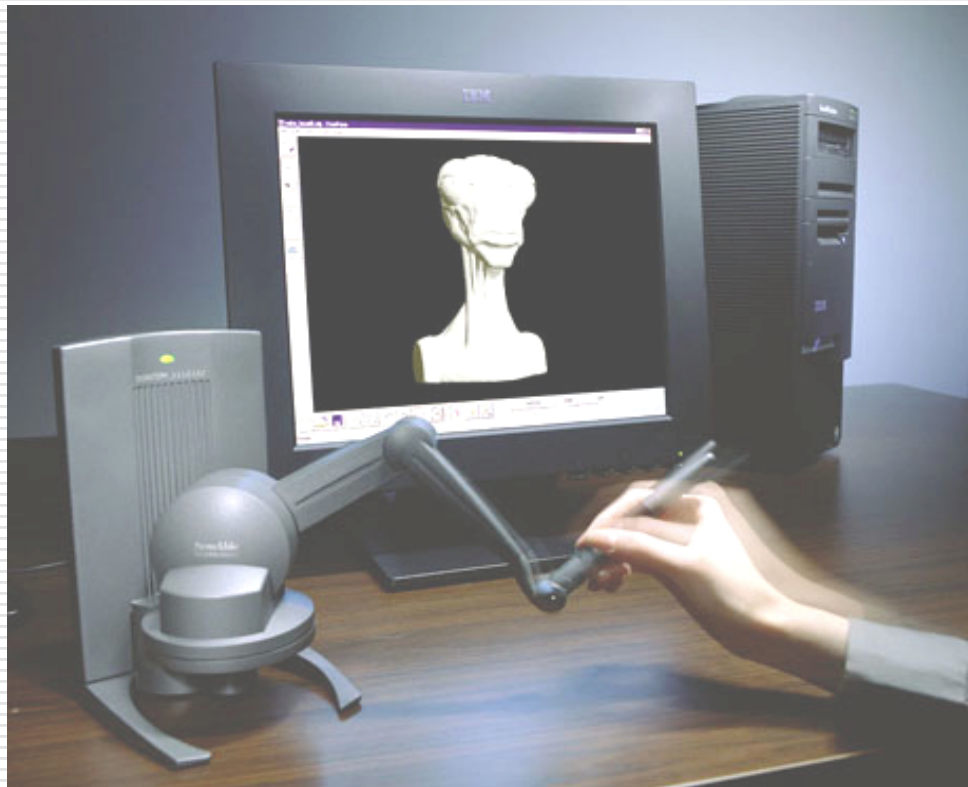

<http://www.sensable.com/>

# Wearable Interaction with Haptics: Immersion *CyberGrasp*

---



<http://www.interaction.com/>

# Wearable Interaction: Rob's *Hand-Held Windows*

---

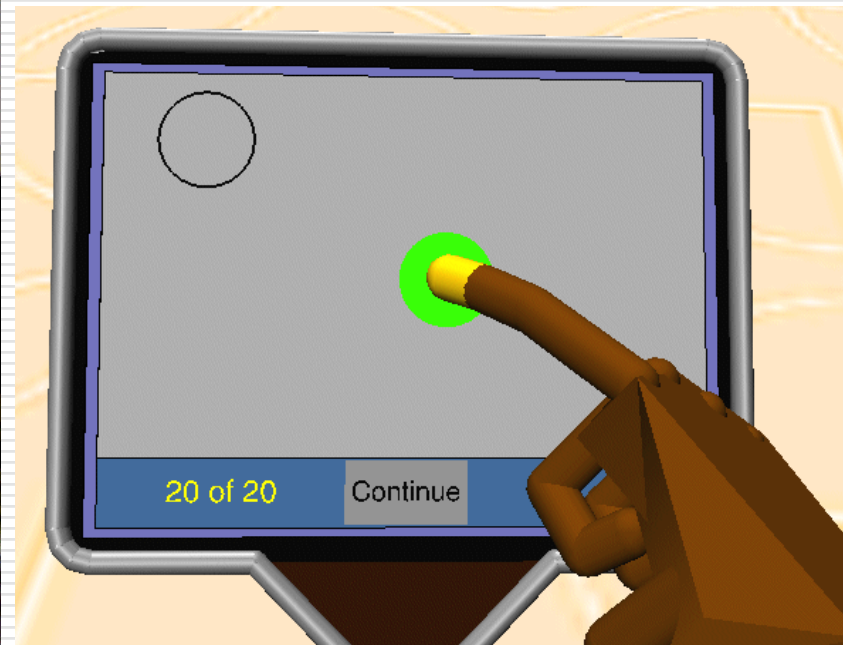

<http://www.cs.wpi.edu/~gmg/>



# How Do We Do Menus?

---

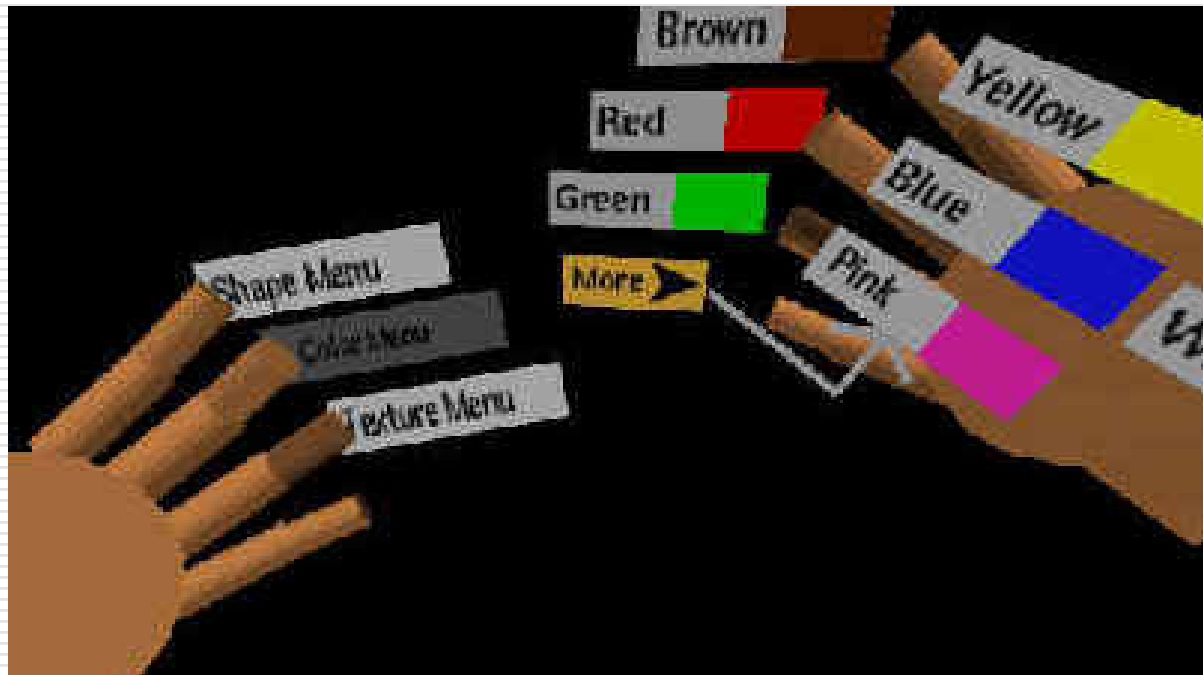

# Interface Devices

---

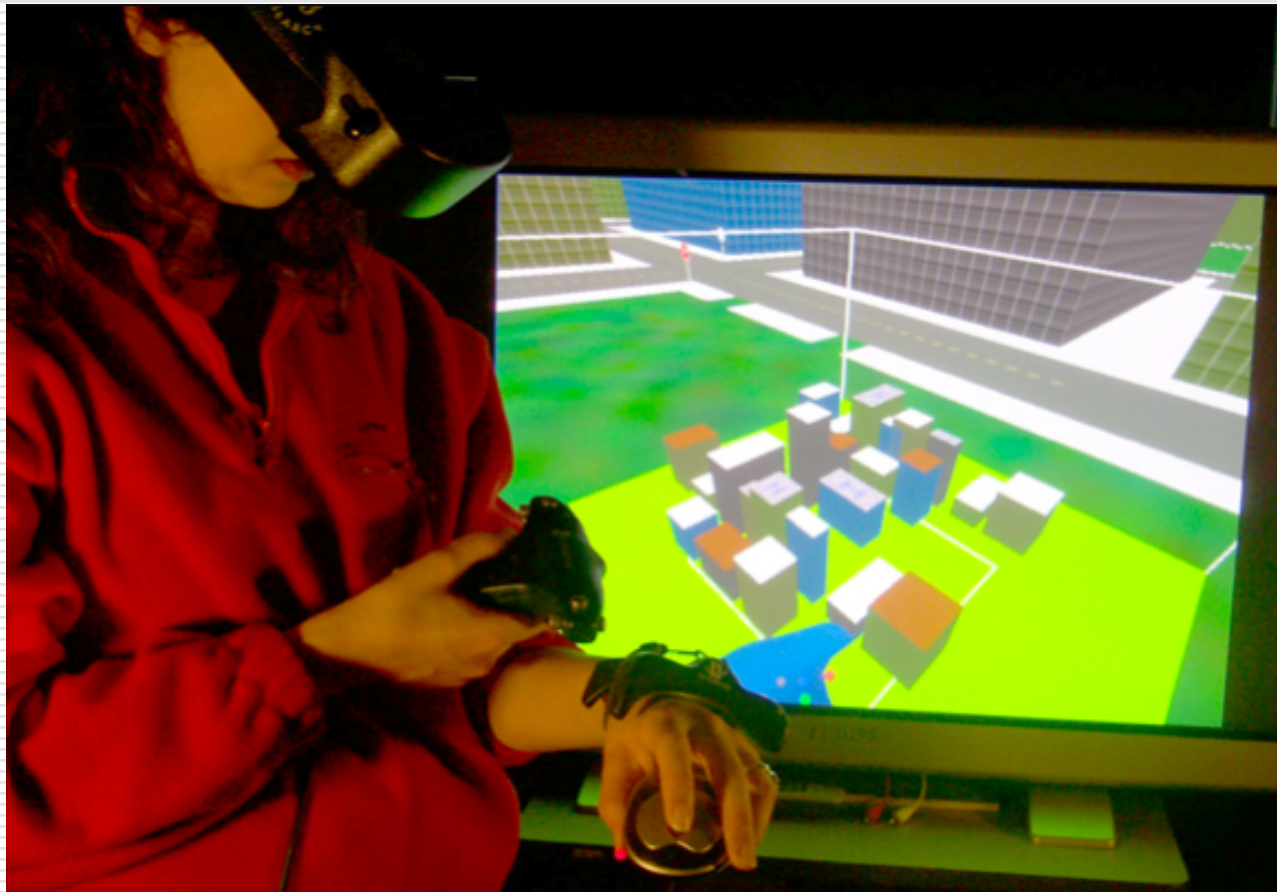

Continuing Virtual Reality

# Augmented Reality (AR)



Copyright © 2011 WPI

## AR (cont.)

---

- Wearable mobile systems emerging
  - Google Glass
  - Epson Moverio
  - Just Android phones with special modifications
  - iPhone 6?

# Google Project Glass

---

- Concept videos
- How does the user interact?