



# Transmission Power Control in Wireless Sensor Networks

CS577 Project by Andrew Keating

# Motivation

- Largely ignored by research community
  - Lower transmission power adds more uncertainty to already complicated problems
  - Only 8 of the CC2420's 31 power levels documented
- Community has mostly focused on conserving power via efficient MAC and Routing layers

# Related Work

- ATPC
  - First dynamic transmission power algorithm for WSN
- DTPC
  - Discovered that low duty cycle MACs benefit most from transmission power control
- ODTPC
  - Employed transmission power control at the routing layer

# Related Work (cont'd)

## ATPC

- Adaptive Transmission Power Control
- Used RSSI and LQI as link quality metrics
  - Found linear relationship between RSSI and PRR

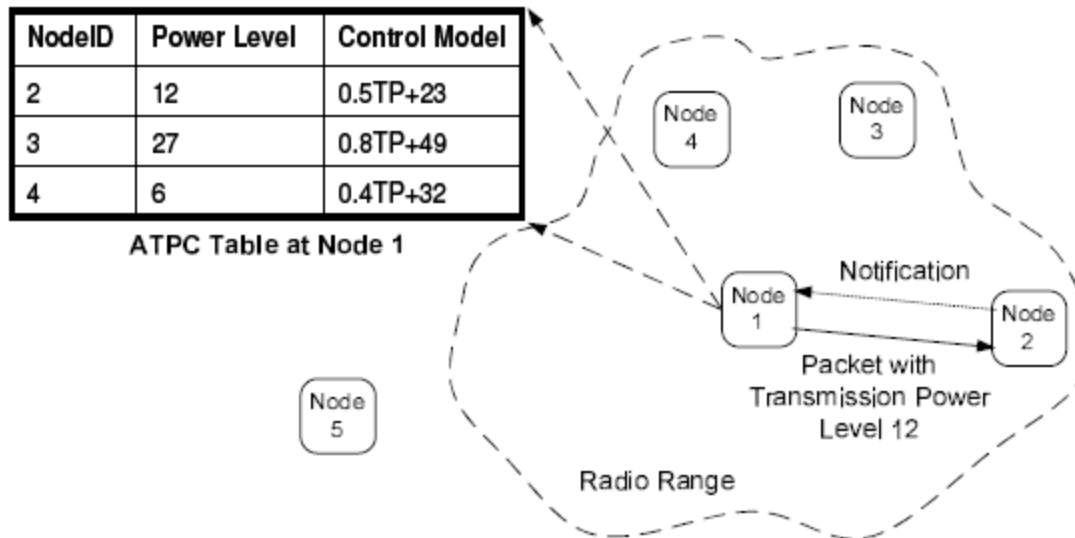

# Related Work (cont'd)

## ART

- Adaptive and Robust Topology Control
- Claim RSSI/LQI not always robust enough for indoor environments
- Zero communication overhead
- Sits in topology layer between MAC and Routing
- Authors considered the impact of topology control on contention

# MAC Layer Architecture (MLA)

- Motivated by numerous monolithic MAC implementations
- Authors discovered reusable components shared by most MAC protocols

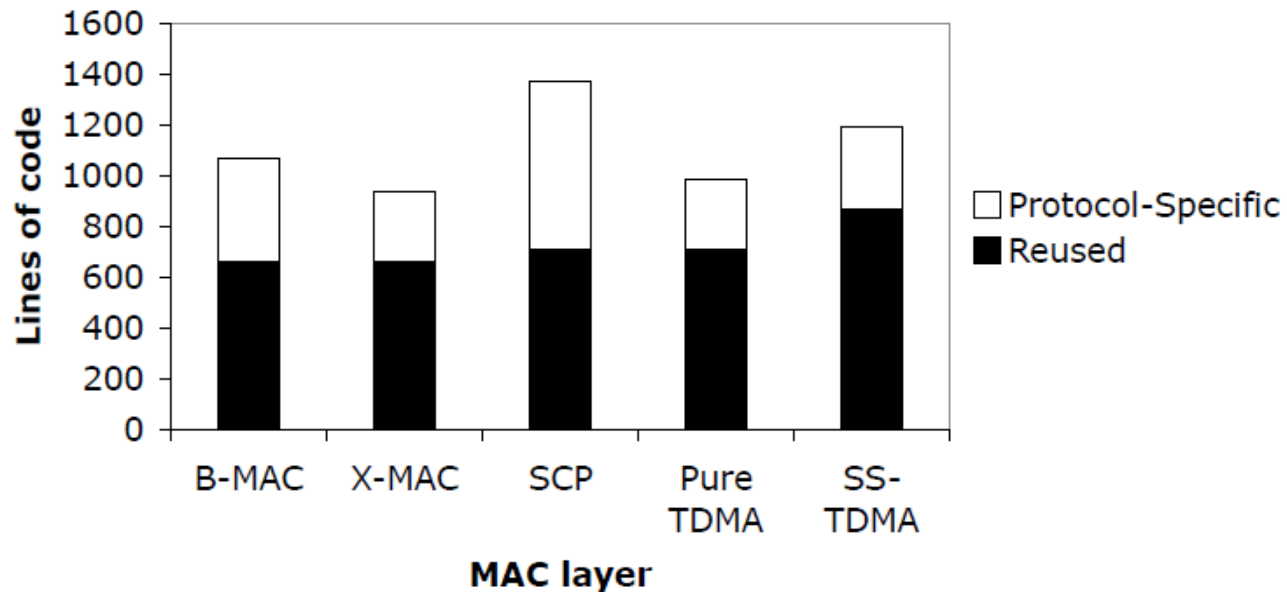

# Crossbow TelosB

- 8MHz MSP430 Microcontroller
- 10 kB RAM
- CC2420 ZigBee Radio (Packet)
- \$100



# CC2420 Power Levels

CC2420 Power Level	Output Power (dBm)	Current Drawn (mA)
31	0	17.4
27	-1	16.5
23	-3	15.2
19	-5	13.9
15	-7	12.5
11	-10	11.2
7	-15	9.9
3	-25	8.5



# MLA Extension

- From SenSys '07 Paper:
- “We note, however, that most existing MAC protocols only utilize one of these low-power states. The implementation of the RadioPowerControl interface must therefore choose the most appropriate one. This interface can be extended to expose multiple power states if future MAC protocols require them.”

# MLA Extension

```
interface RadioPowerControl
{
    /**
     * Turn Power to the Radio On
     */
    async command error_t start();
    event void startDone(error_t error);

    /**
     * Adjust the transmission power of the radio
     */
    async command error_t setPower(uint8_t powerLevel);

    /**
     * Turn Power to the Radio Off
     */
    async command error_t stop();
    event void stopDone(error_t error);
}
```

# Power Control Algorithm

- -80dBm RSSI yields acceptable (99%) PRR with CC2420 [ATPC]
- Each node adjusts its transmission power to neighbors until it establishes RSSI of -80dBm
- Essentially an initialization phase for the network

# RadioRecorder

- Modified TinyOS radio driver
- 32Khz timers capture how long the radio is in each state (idle, sending, receiving)

# Experiments

- Location Selection
  - Found best signal strength on campus
- Overhead Measurement
  - Amount of time to change transmission power
- Dense Convergecast Network
  - Measured potential energy savings

# Experiments (cont'd)

## Location Selection

- Sampled every 250ms for 3 minutes (2ft)

### Signal Strength at Four Locations on WPI Campus

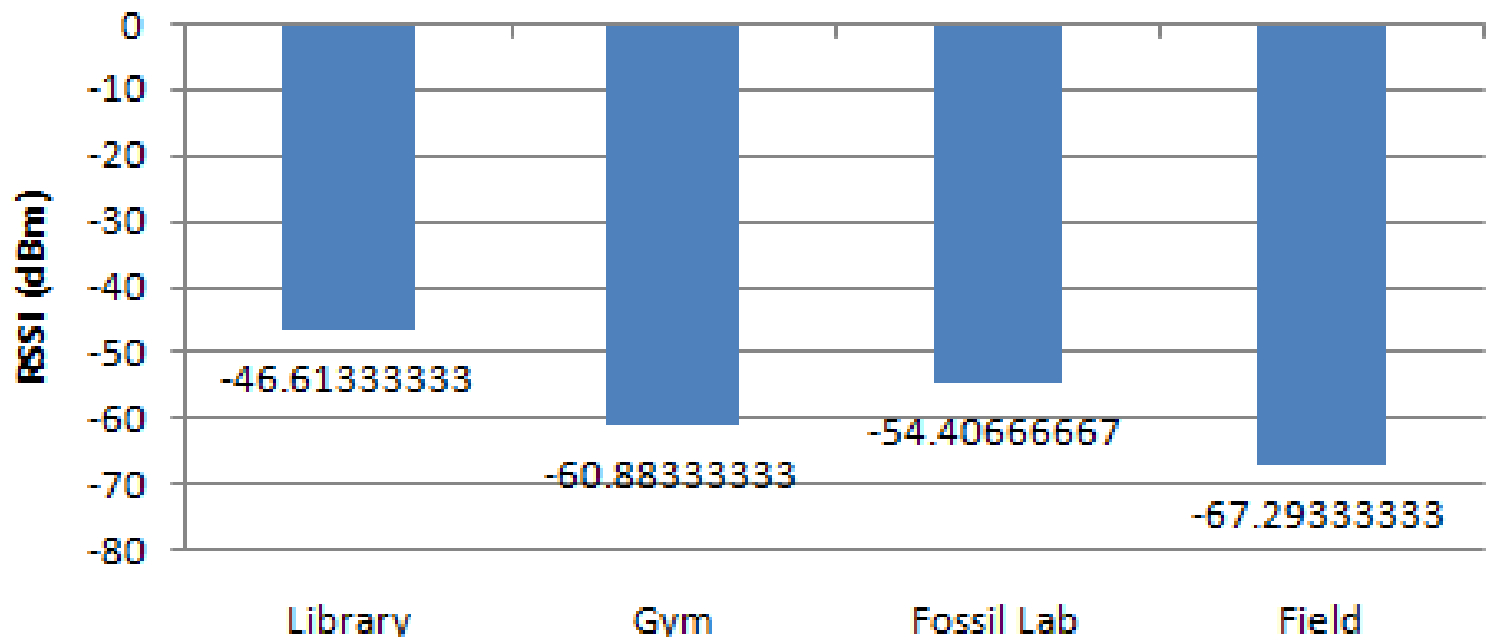

# Experiments (cont'd)

## Overhead Measurement

- Timed 1000 changes of transmission power
- Completely negligible (microseconds)
- Upon further investigation, this is simply the setting of a register value

# Experiments (cont'd)

## AS-MAC Parameters

- 50-byte data packets
- Hello packets disabled
- Static initialization of neighbor table
- 1000ms wakeup interval
- 5ms LPL duration
- 16-slot CW, 5ms slots (80ms total)



# Experiments (cont'd)

## Energy Measurement Setup



# Results

CC2420 Power Level	Output Power (dBm)	Total Energy Consumed (mJ)	Energy Consumed Sending (mJ)
31	0	149.07	50.86
3	-25	123.88	24.87

- 100% packet reception ratio
- 51.1% less energy sending
- 16.8% less energy total

# Conclusions

- In some cases, it is possible to reduce power consumption without degrading link quality via transmission power reduction
- Many factors affect wireless signals, so the best solution is dynamic power control
- Community should pay more attention to this problem

# Future Work

- Routing
  - Choose routing path based on amount of signal strength required
- Clustering
  - Reduce signal strength to create clusters – reduce collisions