

Introduction to Congestion Control



Principles of Congestion Control

Congestion:

- informally: “too many sources sending too much data too fast for the **network** to handle”
- different from flow control!
- manifestations:
 - lost packets (buffer overflow at routers)
 - long delays (queueing in router buffers)
- a major problem in networking!

Causes/Costs of Congestion

Scenario 1

- two senders, two receivers
- one router, infinite buffers
- no retransmission

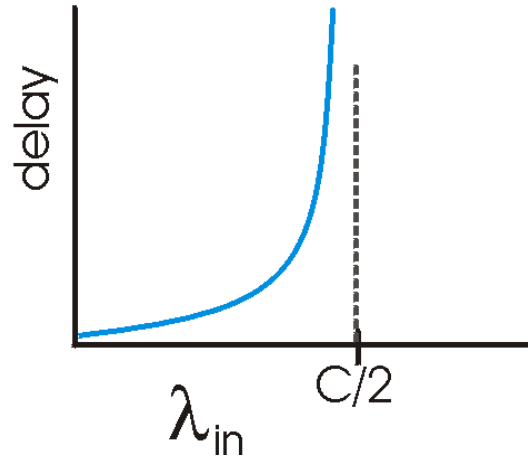
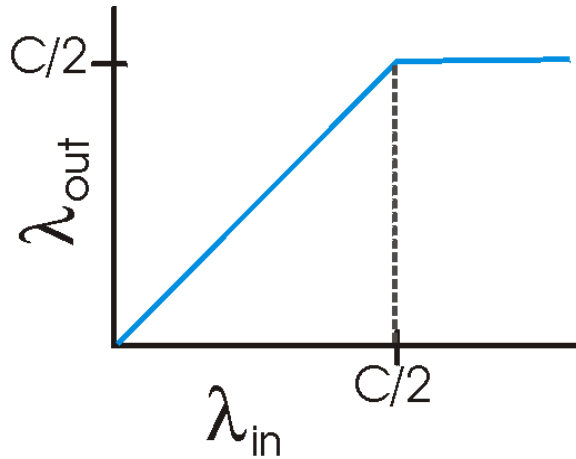
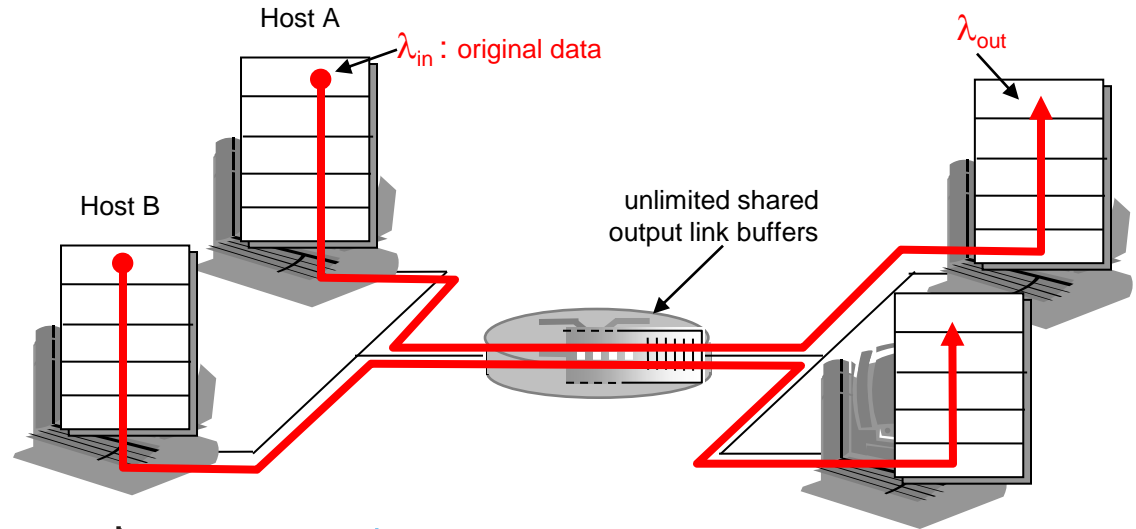

- large delays when congested
- maximum achievable throughput

Causes/Costs of Congestion

Scenario 2

- one router, *finite* buffers
- sender retransmission of lost packet

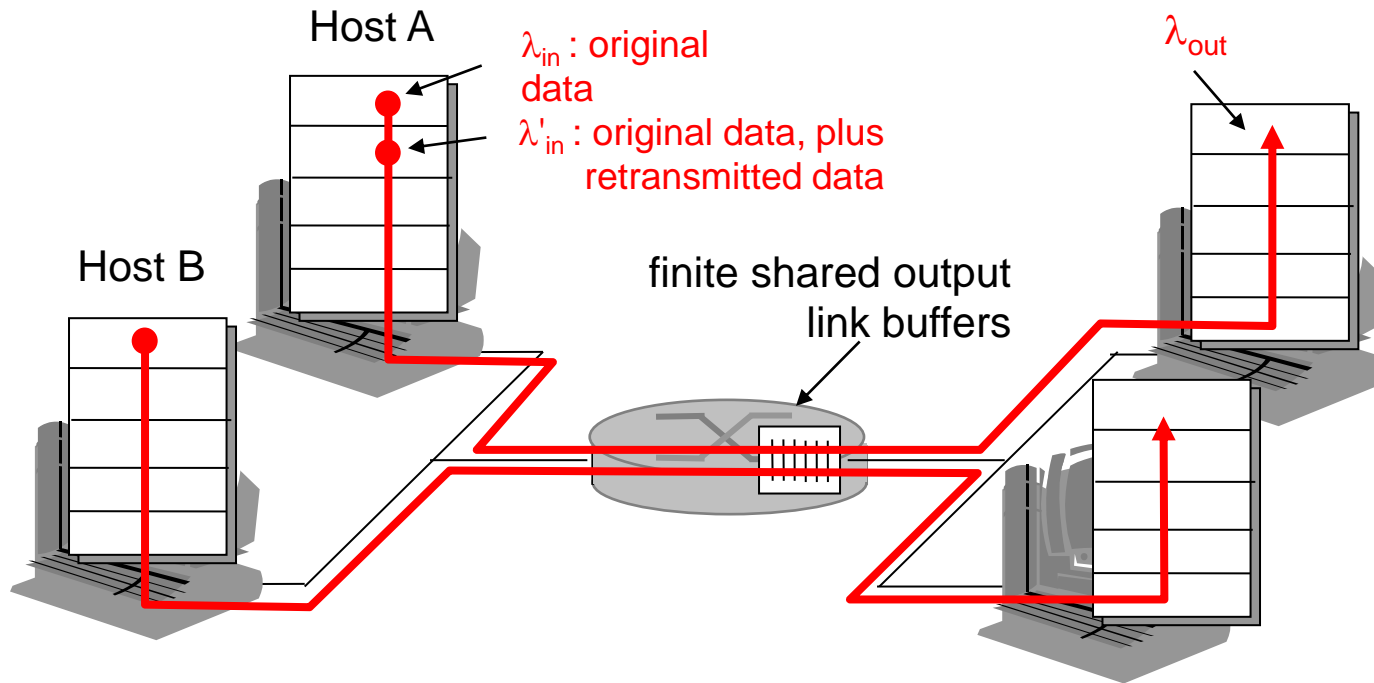

Causes/Costs of Congestion

Scenario 2

- always: $\lambda_{in} = \lambda_{out}$ (goodput)
- “perfect” retransmission only when loss: $\lambda'_{in} > \lambda_{out}$
- retransmission of delayed (not lost) packet makes λ'_{in} larger (than perfect case) for same λ_{out}

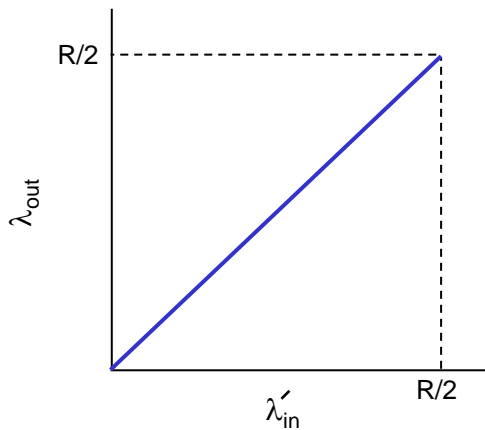

a.

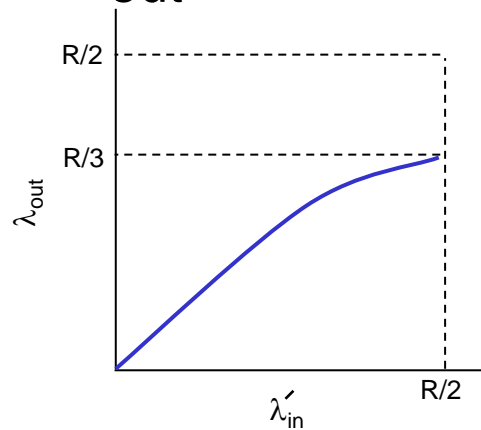

b.

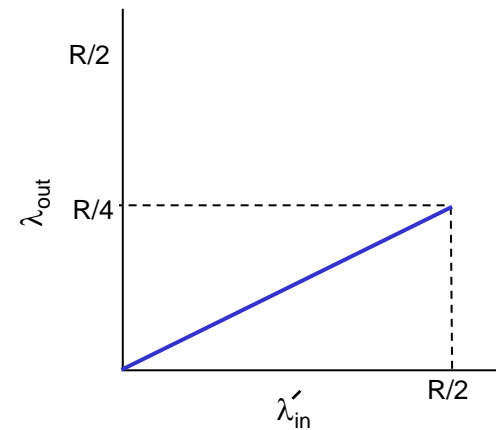

c.

“costs” of congestion:

- more work (retransmissions) for a given “goodput”
- unneeded retransmissions: link carries multiple copies of packet

Approaches towards Congestion Control

Two broad approaches towards congestion control:

end-end congestion control:

- no explicit feedback from network
- congestion **inferred** from end-system observed loss, delay
- approach taken by TCP

network-assisted congestion control:

- routers provide feedback to end systems
 - single bit indicating congestion (SNA, DECbit, TCP/IP ECN, ATM)
 - explicit rate sender should use for sending.

TCP

Congestion Control

Lecture material taken from
“Computer Networks *A Systems Approach*”,
Fourth Edition, Peterson and Davie,
Morgan Kaufmann, 2007.

TCP Congestion Control

- **Essential strategy** :: The TCP host sends packets into the network without a reservation and then the host reacts to observable events.
- Originally TCP assumed FIFO queuing.
- **Basic idea** :: each source determines how much capacity is available to a given flow in the network.
- **ACKs** are used to ‘*pace*’ the transmission of packets such that TCP is “self-clocking”.

TCP Congestion Control

K & R

- **Goal:** TCP sender should transmit as fast as possible, but without congesting network.
 - **issue** - how to find rate *just below* congestion level?
- Each TCP sender sets its window size, based on *implicit* feedback:
 - **ACK** segment received → network is not congested, so increase sending rate.
 - **lost segment** - assume loss due to congestion, so decrease sending rate.

TCP Congestion Control

K & R

- **“probing for bandwidth”**: increase transmission rate on receipt of ACK, until eventually loss occurs, then decrease transmission rate
 - continue to increase on ACK, decrease on loss (since available bandwidth is changing, depending on other connections in network).

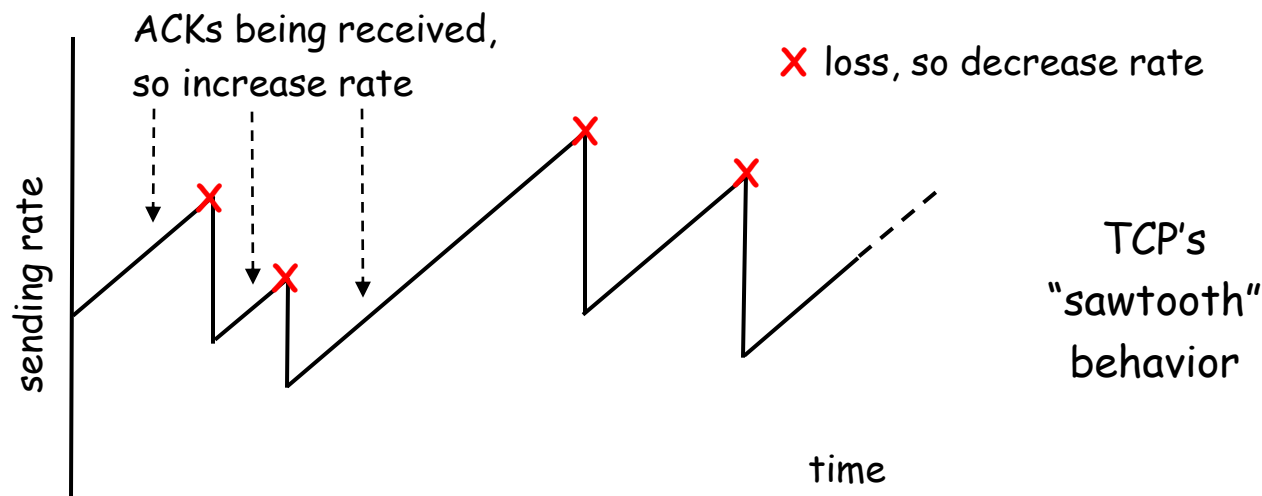

- Q: how fast to increase/decrease?

AIMD

(Additive Increase / Multiplicative Decrease)

- CongestionWindow (**cwnd**) is a variable held by the TCP source for each connection.

MaxWindow :: min (CongestionWindow , AdvertisedWindow)

EffectiveWindow = MaxWindow – (LastByteSent - LastByteAcked)

- **cwnd** is set based on the perceived level of congestion. The Host receives *implicit* (packet drop) or *explicit* (packet mark) indications of internal congestion.

Additive Increase (AI)

- Additive Increase is a reaction to perceived available capacity (referred to as **congestion avoidance** stage).
- Frequently in the literature, additive increase is defined by parameter α (where the default is $\alpha = 1$).
- **Linear Increase** :: For each “cwnd’s worth” of packets sent, increase cwnd by 1 packet.
- In practice, **cwnd** is incremented fractionally for each arriving ACK.

$$\text{increment} = \text{MSS} \times (\text{MSS} / \text{cwnd})$$

$$\text{cwnd} = \text{cwnd} + \text{increment}$$

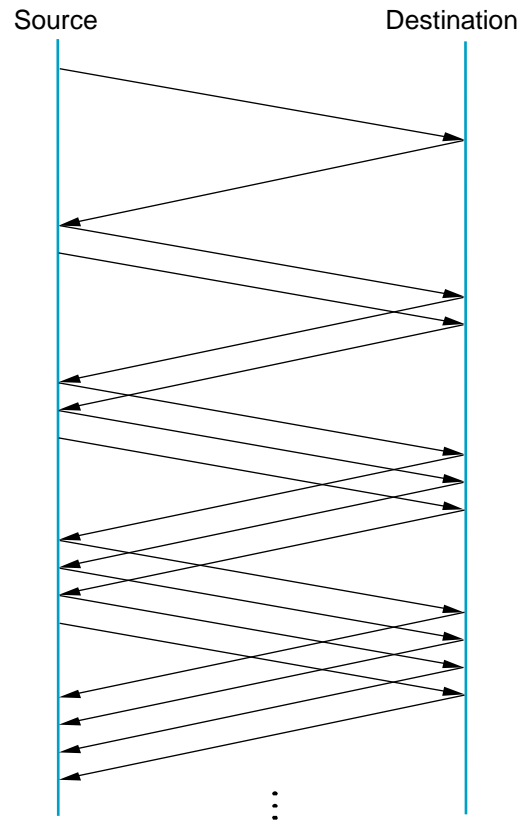

Add one packet
each RTT

Figure 6.8 Additive Increase

Multiplicative Decrease (MD)

- * Key assumption :: a dropped packet and resultant timeout are due to congestion at a router.
- Frequently in the literature, multiplicative decrease is defined by parameter β (where the default is $\beta = 0.5$)

Multiplicate Decrease:: TCP reacts to a timeout by halving **cwnd**.

- Although defined in bytes, the literature often discusses **cwnd** in terms of packets (or more formally in MSS == Maximum Segment Size).
- **cwnd** is not allowed below the size of a single packet.

AIMD

(Additive Increase / Multiplicative Decrease)

- It has been shown that AIMD is a necessary condition for TCP congestion control to be stable.
- Because the simple CC mechanism involves timeouts that cause retransmissions, it is important that hosts have an accurate timeout mechanism.
- Timeouts set as a function of average RTT and standard deviation of RTT.
- However, TCP hosts only sample round-trip time once per RTT using coarse-grained clock.

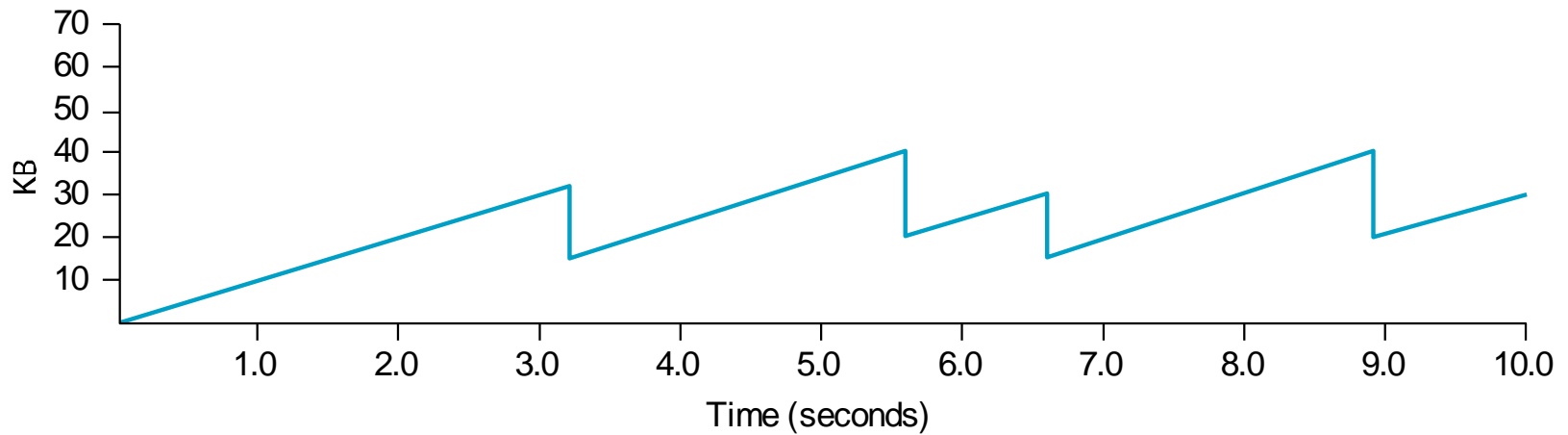

**Figure 6.9 Typical TCP
Sawtooth Pattern**

Slow Start

- Linear additive increase takes too long to ramp up a new TCP connection from cold start.
- Beginning with TCP Tahoe, the **slow start mechanism** was added to provide an initial exponential increase in the size of **cwnd**.

*Remember mechanism by: **slow start prevents a slow start. Moreover, slow start is slower than sending a full advertised window's worth of packets all at once.***

Slow Start

- The source starts with $cwnd = 1$.
- Every time an ACK arrives, $cwnd$ is incremented.
- $cwnd$ is effectively doubled per RTT “epoch”.
- Two **slow start** situations:
 - At the very beginning of a connection **{cold start}**.
 - When the connection goes dead waiting for a timeout to occur (i.e, when the **advertized window** goes to zero!)

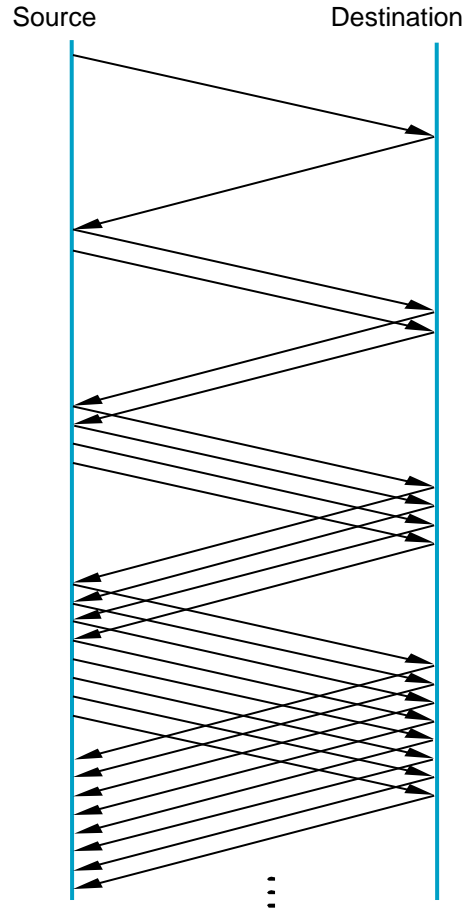

Slow Start
Add one packet
per ACK

Figure 6.10 Slow Start

Slow Start

- However, in the second case the source has more information. The current value of cwnd can be saved as a **congestion threshold**.
- This is also known as the “slow start threshold” **ssthresh**.

Slow Start

Congestion Window

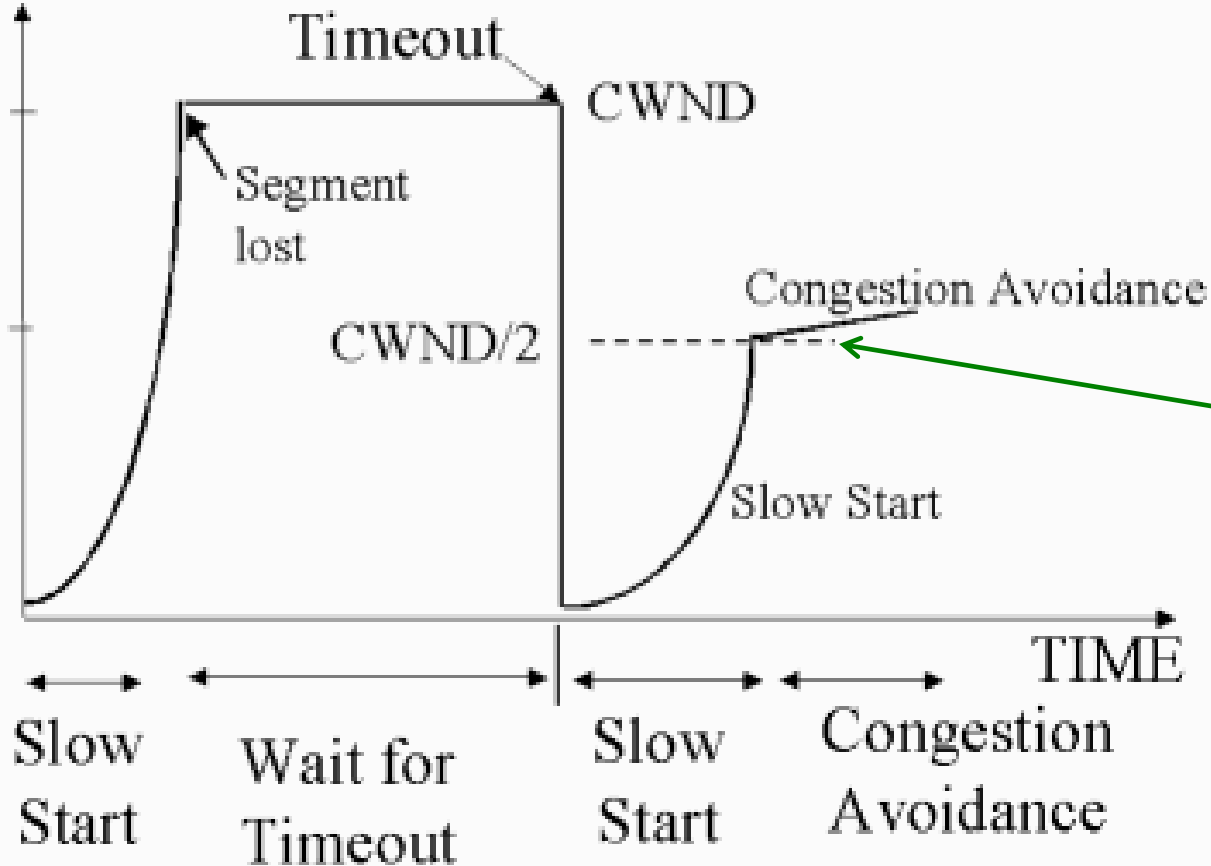

$ssthresh$

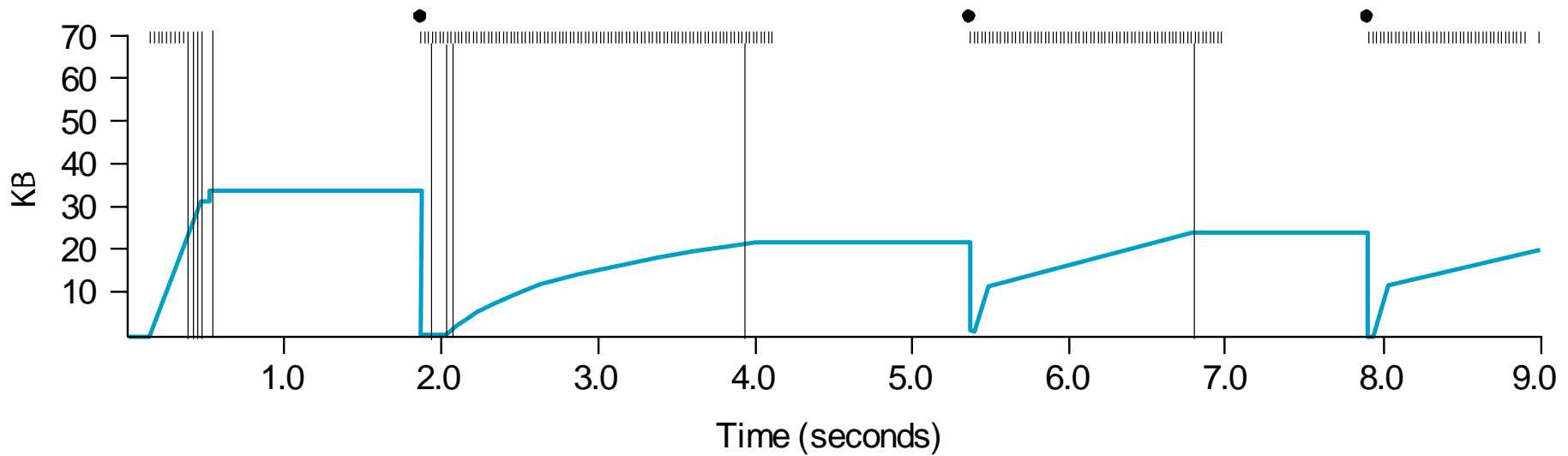

**Figure 6.11 Behavior of TCP
Congestion Control**

Fast Retransmit

- Coarse timeouts remained a problem, and **Fast retransmit** was added with **TCP Tahoe**.
- Since the receiver responds every time a packet arrives, this implies the sender will see duplicate ACKs.

Basic Idea:: *use **duplicate ACKs** to signal lost packet.*

Fast Retransmit

Upon receipt of **three** duplicate ACKs, the TCP Sender retransmits the lost packet.

Fast Retransmit

- Generally, **fast retransmit** eliminates about half the coarse-grain timeouts.
- This yields roughly a 20% improvement in throughput.
- Note – **fast retransmit** does not eliminate all the timeouts due to small window sizes at the source.

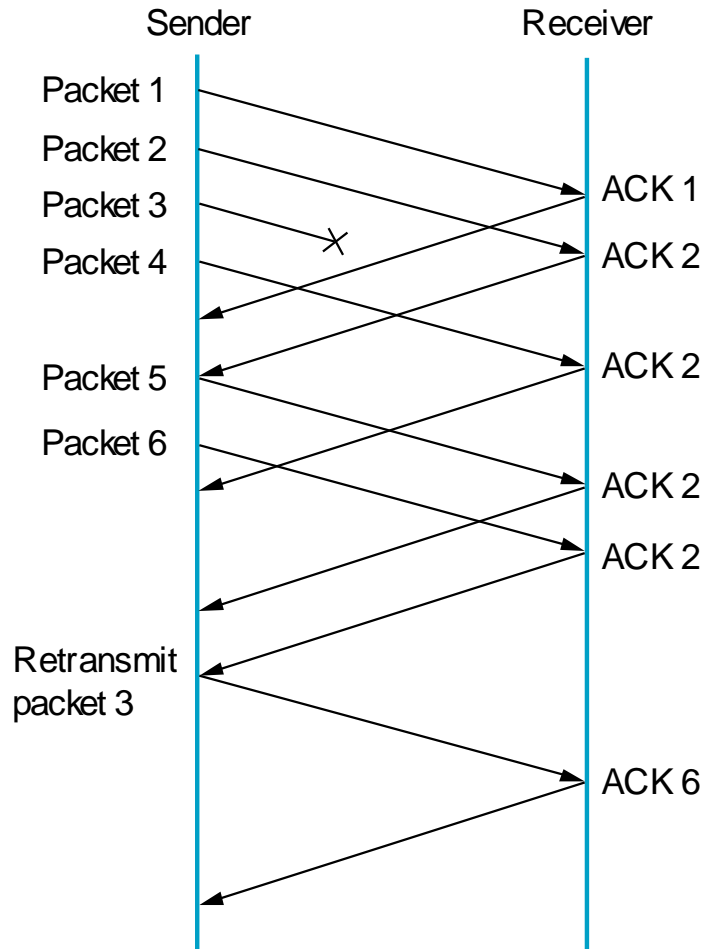

Fast Retransmit

Based on three duplicate ACKs

Figure 6.12 Fast Retransmit

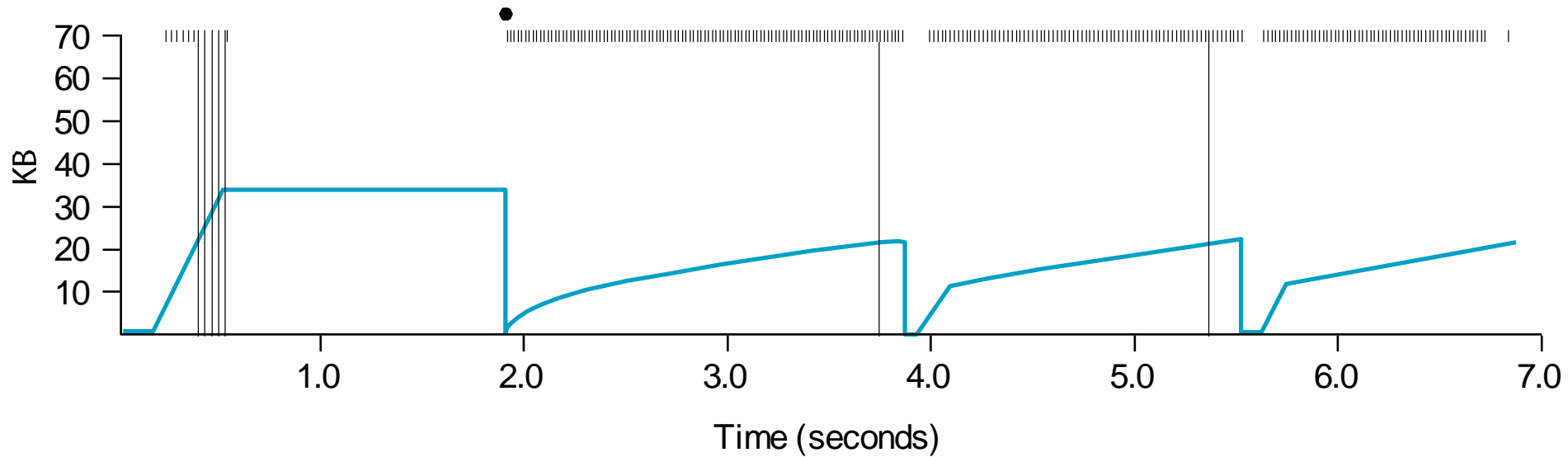

Figure 6.13 TCP Fast Retransmit Trace

Fast Recovery

- **Fast recovery** was added with **TCP Reno**.
- **Basic idea::** When **fast retransmit** detects three duplicate ACKs, start the recovery process from congestion avoidance region and use ACKs in the pipe to pace the sending of packets.

Fast Recovery

After Fast Retransmit, half **cwnd** and commence recovery from this point using linear additive increase 'primed' by left over ACKs in pipe.

Modified Slow Start

- With **fast recovery**, **slow start** only occurs:
 - At cold start
 - After a coarse-grain timeout
- *This is the difference between*
TCP Tahoe *and* **TCP Reno!!**

Many TCP 'flavors'

- TCP New Reno
- TCP SACK
 - requires sender and receiver both to support TCP SACK
 - possible state machine is complex.
- TCP Vegas
 - adjusts window size based on difference between expected and actual RTT.
- TCP Cubic

Figure 5.6 Three-way TCP Handshake

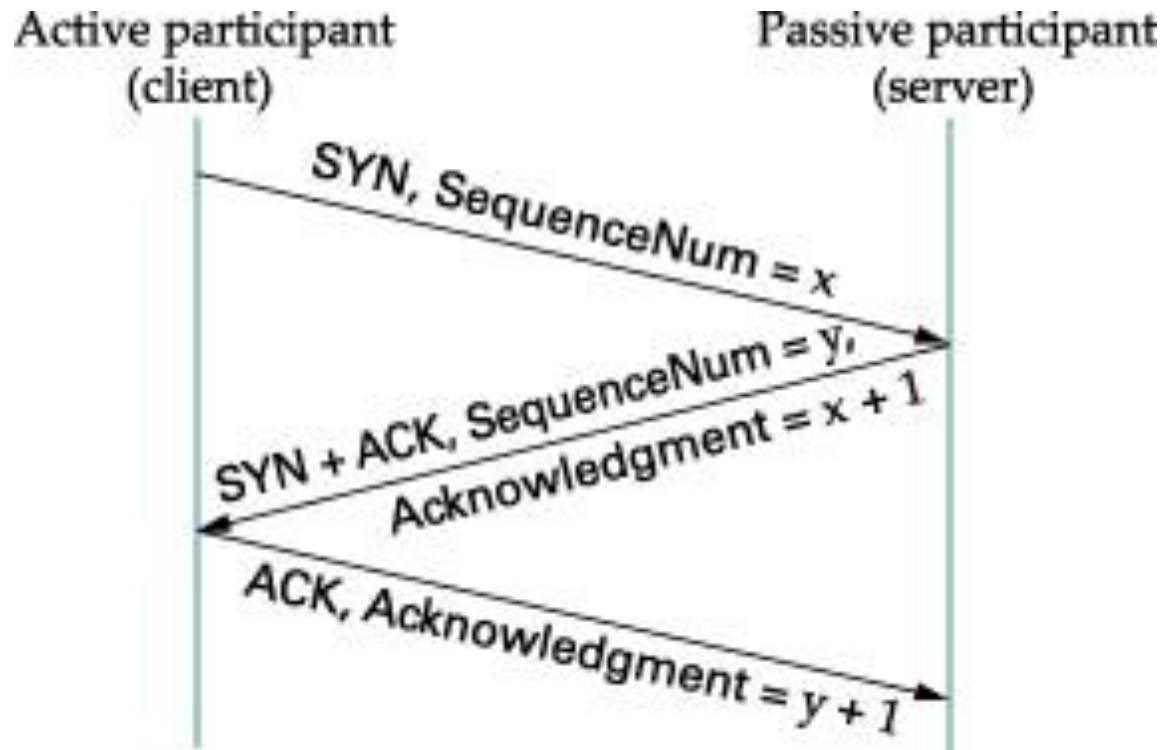

Adaptive Retransmissions

RTT:: Round Trip Time between a pair of hosts on the Internet.

- How to set the Timeout value (RTO)?
 - The timeout value is set as a function of the expected RTT.
 - Consequences of a bad choice?

Original Algorithm

- Keep a running average of RTT and compute TimeOut as a function of this RTT.
 - Send packet and keep timestamp t_s .
 - When ACK arrives, record timestamp t_a .

$$\text{SampleRTT} = t_a - t_s$$

Original Algorithm

Compute a weighted average:

$$\text{EstimatedRTT} = \alpha \times \text{EstimatedRTT} + (1 - \alpha) \times \text{SampleRTT}$$

Original TCP spec: α in range (0.8,0.9)

$$\text{TimeOut} = 2 \times \text{EstimatedRTT}$$

Karn/Partridge Algorithm

An obvious flaw in the original algorithm:

Whenever there is a retransmission it is impossible to know whether to associate the ACK with the original packet or the retransmitted packet.

Figure 5.10 Associating the ACK?

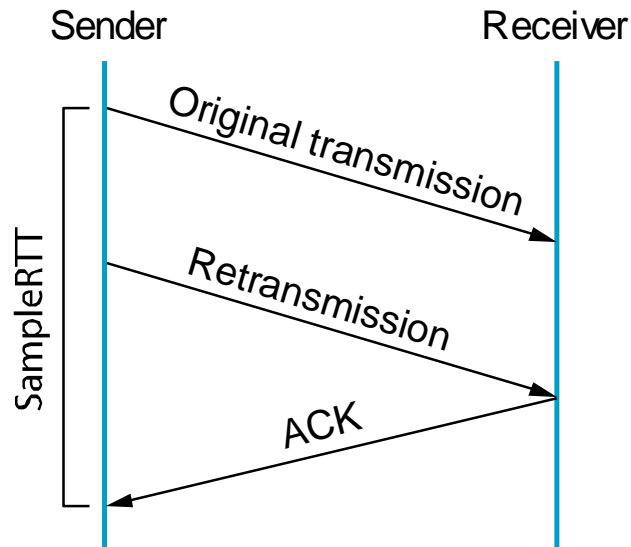

(a)

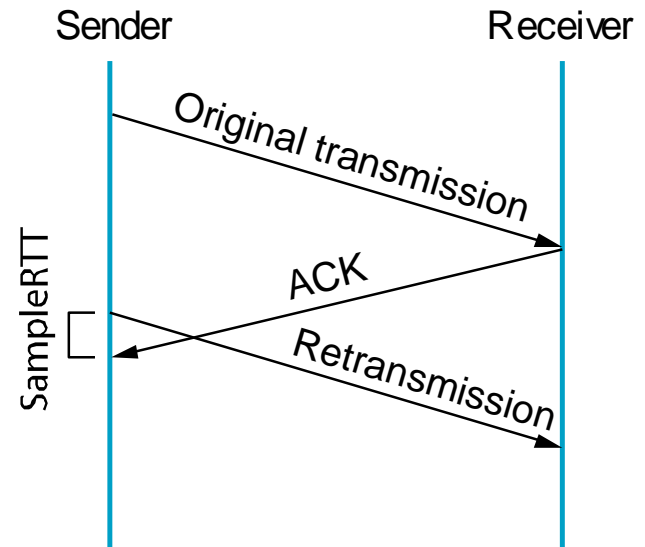

(b)

Karn/Partridge Algorithm

1. Do not measure **SampleRTT** when sending packet more than once.
2. For each retransmission, set **TimeOut** to **double** the last **TimeOut**.

{ Note – this is a form of exponential backoff based on the believe that the lost packet is due to **congestion**. }

Jacobson/Karels Algorithm

The problem with the original algorithm is that it did not take into account the variance of SampleRTT.

Difference = SampleRTT – EstimatedRTT

EstimatedRTT = EstimatedRTT +

(δ x Difference)

Deviation = δ (|Difference| - Deviation)

where δ is a fraction between 0 and 1.

Jacobson/Karels Algorithm

TCP computes timeout using both the mean and variance of RTT

$$\text{TimeOut} = \mu \times \text{EstimatedRTT} + \Phi \times \text{Deviation}$$

where based on experience $\mu = 1$ and $\Phi = 4$.

TCP Congestion Control Summary

- TCP interacts with routers in the subnet and reacts to implicit congestion notification (packet drop) by reducing the TCP sender's congestion window.
- TCP increases congestion window using slow start or congestion avoidance.
- Currently, the two most common versions of TCP are New Reno and Cubic.

TCP New Reno

- Two problem scenarios with TCP Reno
 - bursty losses, Reno cannot recover from bursts of 3+ losses
 - Packets arriving out-of-order can yield duplicate acks when in fact there is no loss.
- New Reno solution – try to determine the end of a burst loss.

TCP New Reno

- When duplicate ACKs trigger a retransmission for a lost packet, remember the highest packet sent from window in **recover**.
- Upon receiving an ACK,
 - if $\text{ACK} < \text{recover} \Rightarrow$ partial ACK
 - If $\text{ACK} \geq \text{recover} \Rightarrow$ new ACK

TCP New Reno

- Partial ACK implies another lost packet: retransmit next packet, inflate window and stay in fast recovery.
- New ACK implies fast recovery is over: starting from $0.5 \times \text{cwnd}$ proceed with congestion avoidance (linear increase).
- New Reno recovers from n losses in n round trips.