

# Data Link Layer

# Data Link Layer

- Provides a *well-defined service interface* to the network layer.
- Determines how the bits of the physical layer are grouped into frames (*framing*).
- Deals with transmission errors (**CRC and ARQ**).
- Regulates the flow of frames.
- Performs general link layer management.

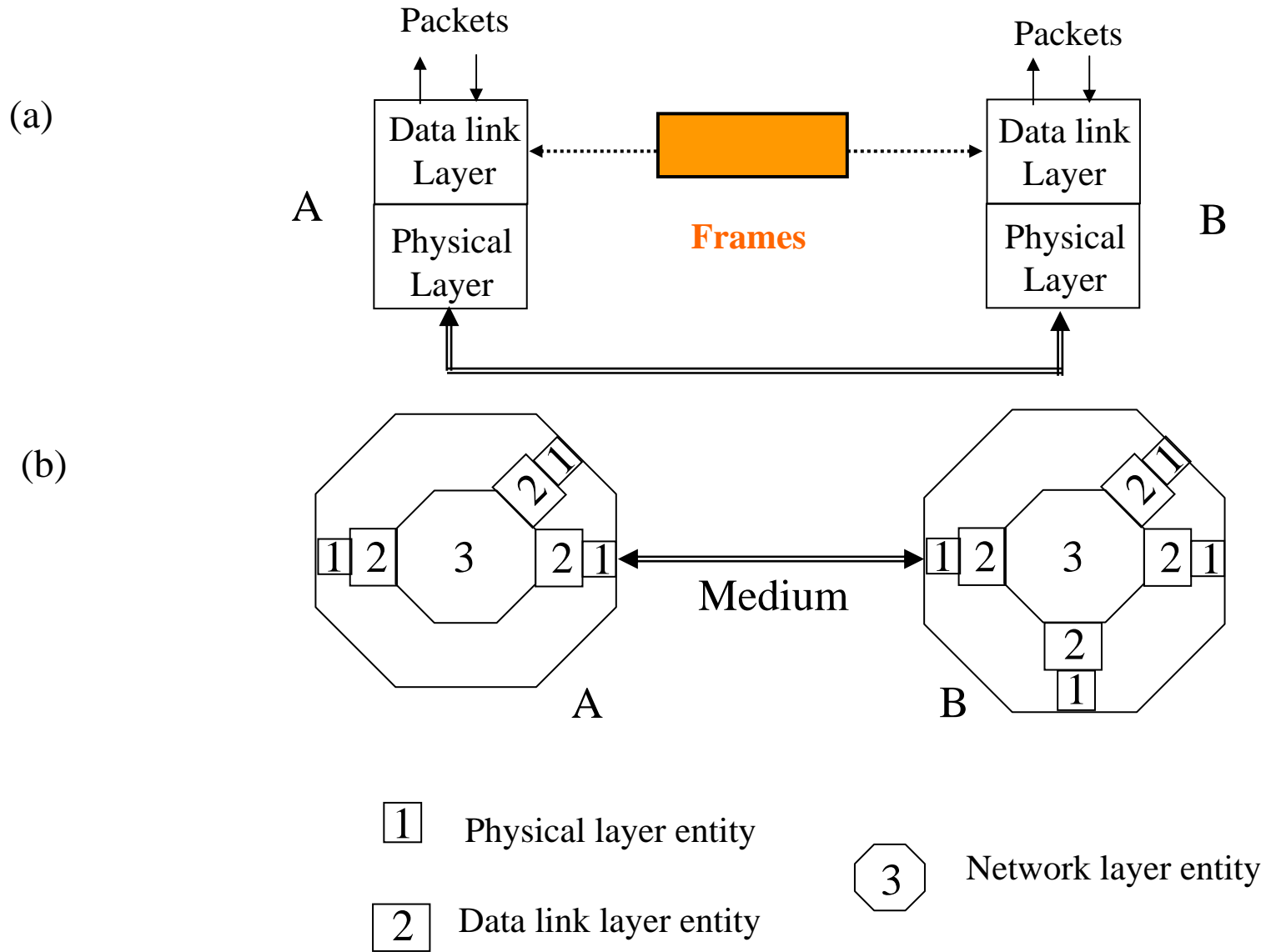

# End to End

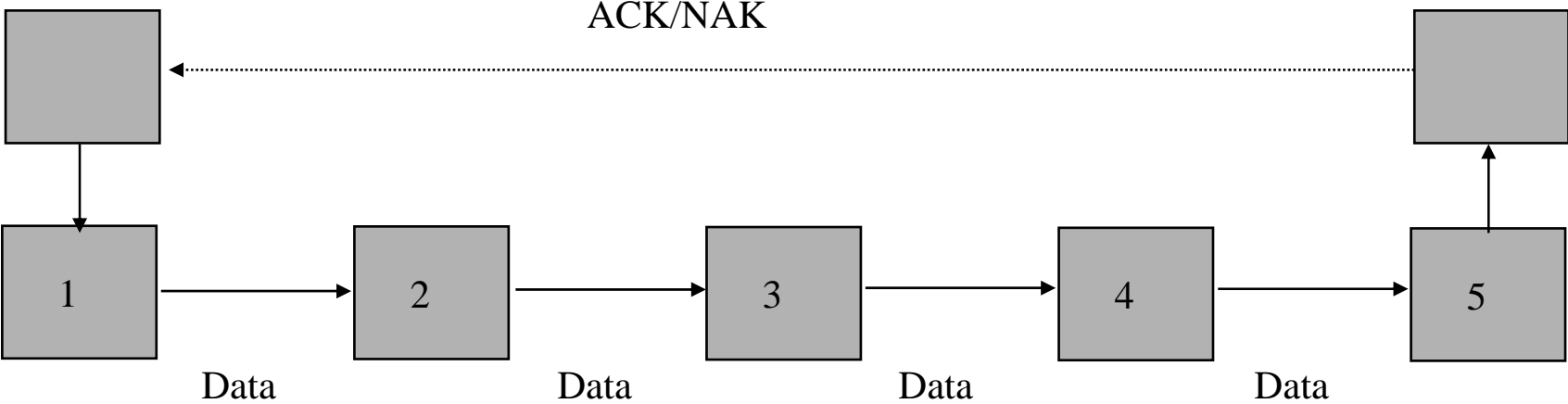

# Hop by Hop

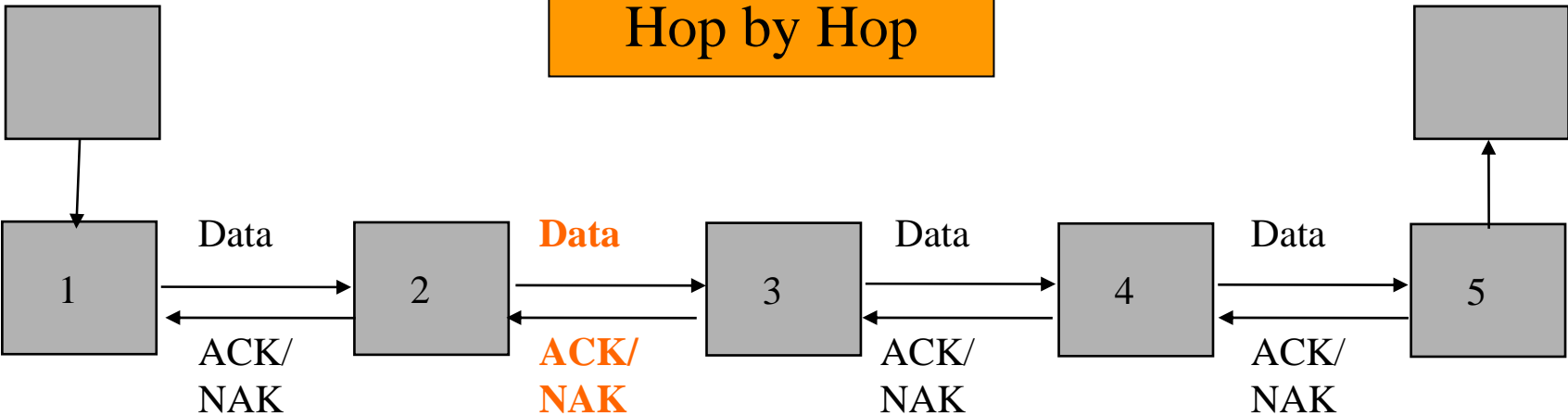

Figure 5.7

Leon-Garcia & Widjaja: *Communication Networks*

Copyright ©2000 The McGraw Hill Companies



# Tanenbaum's Data Link Layer Treatment

- Concerned with communication between two adjacent nodes in the subnet (node to node).
- Assumptions:
  - The bits are delivered in the order sent.
  - **Rigid interface** between the HOST and the node  
→ *the communications policy and the Host protocol (with OS effects) can evolve separately.*
  - He uses a simplified model.

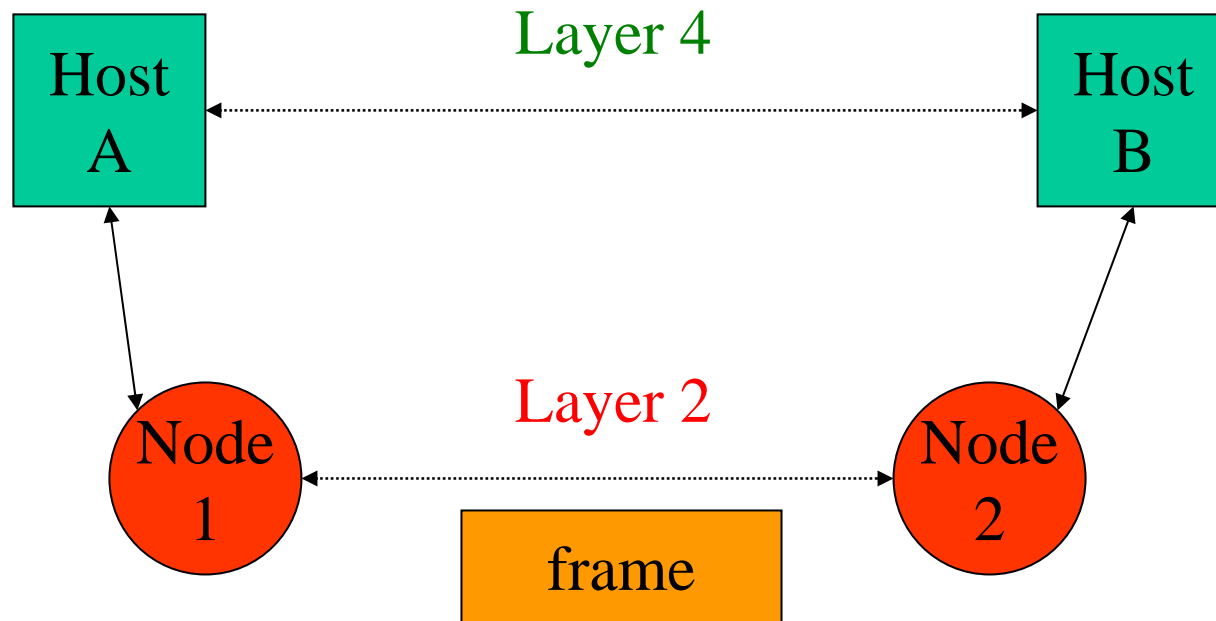

## Data Link Layer Model

Assume the sending Host has *infinite* supply of messages.

A node constructs a *frame* from a *single packet message*.

The CRC is automatically appended in the hardware.

The protocols are developed in increasing complexity to help students understand the data link layer issues.

# Basic Elements of ARQ

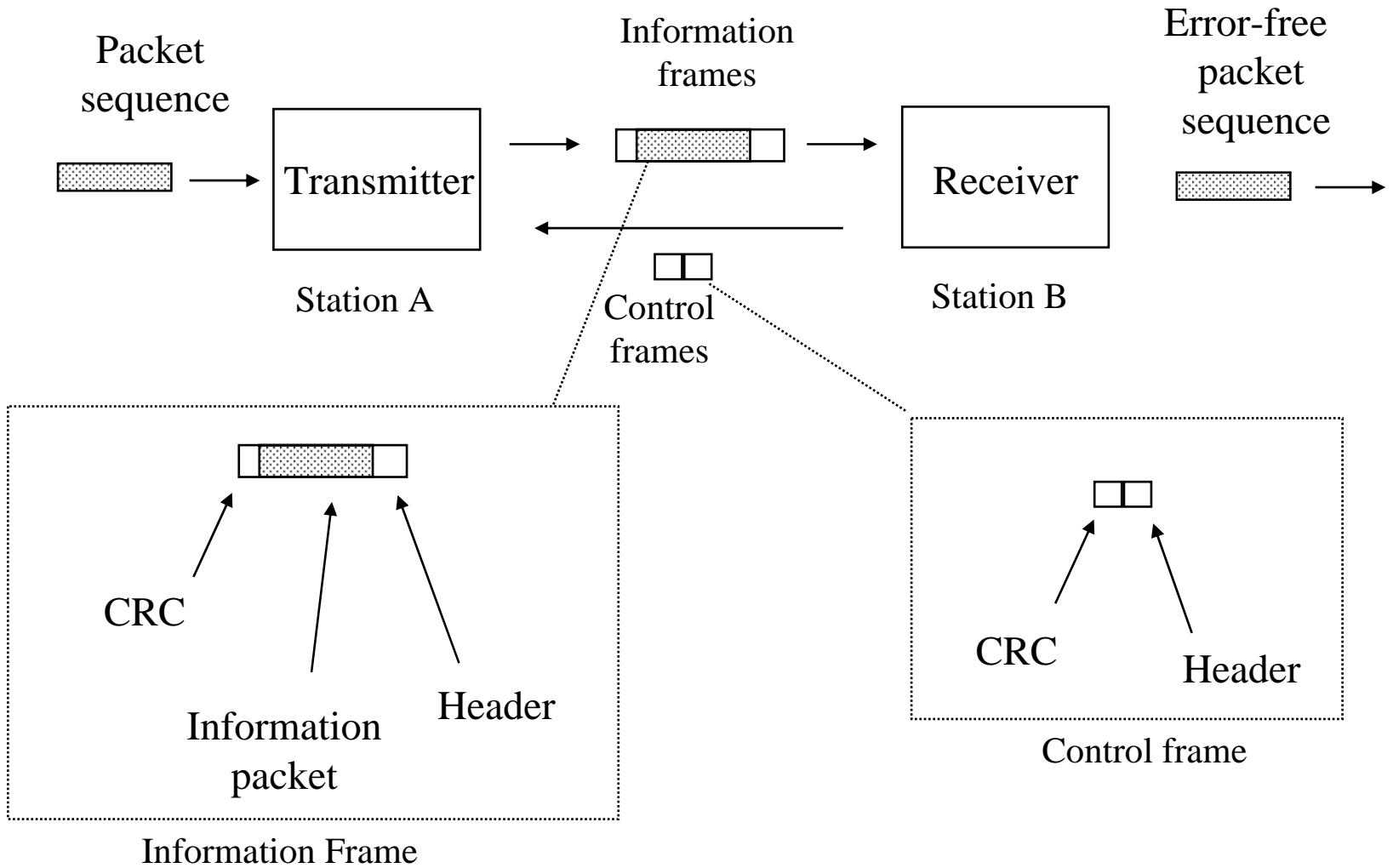

# Tanenbaum's Protocol Definitions

```
#define MAX_PKT 1024                                /* determines packet size in bytes */

typedef enum {false, true} boolean;                 /* boolean type */
typedef unsigned int seq_nr;                         /* sequence or ack numbers */
typedef struct {unsigned char data[MAX_PKT];} packet; /* packet definition */
typedef enum {data, ack, nak} frame_kind;           /* frame_kind definition */

typedef struct {                                     /* frames are transported in this layer */
    frame_kind kind;                                /* what kind of a frame is it? */
    seq_nr seq;                                     /* sequence number */
    seq_nr ack;                                     /* acknowledgement number */
    packet info;                                     /* the network layer packet */
} frame;
```

Continued →

Figure 3-9. Some definitions needed in the protocols to follow. These are located in the file protocol.h.



# Protocol Definitions (continued)

Figure 3-9. Some definitions needed in the protocols to follow. These are located in the file protocol.h.

```
/* Wait for an event to happen; return its type in event. */  
void wait_for_event(event_type *event);  
  
/* Fetch a packet from the network layer for transmission on the channel. */  
void from_network_layer(packet *p);  
  
/* Deliver information from an inbound frame to the network layer. */  
void to_network_layer(packet *p);  
  
/* Go get an inbound frame from the physical layer and copy it to r. */  
void from_physical_layer(frame *r);  
  
/* Pass the frame to the physical layer for transmission. */  
void to_physical_layer(frame *s);  
  
/* Start the clock running and enable the timeout event. */  
void start_timer(seq_nr k);  
  
/* Stop the clock and disable the timeout event. */  
void stop_timer(seq_nr k);  
  
/* Start an auxiliary timer and enable the ack_timeout event. */  
void start_ack_timer(void);  
  
/* Stop the auxiliary timer and disable the ack_timeout event. */  
void stop_ack_timer(void);  
  
/* Allow the network layer to cause a network_layer_ready event. */  
void enable_network_layer(void);  
  
/* Forbid the network layer from causing a network_layer_ready event. */  
void disable_network_layer(void);  
  
/* Macro inc is expanded in-line: Increment k circularly. */  
#define inc(k) if (k < MAX_SEQ) k = k + 1; else k = 0
```

packet

network layer

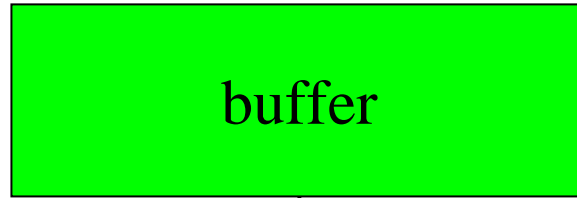

frame

data link layer

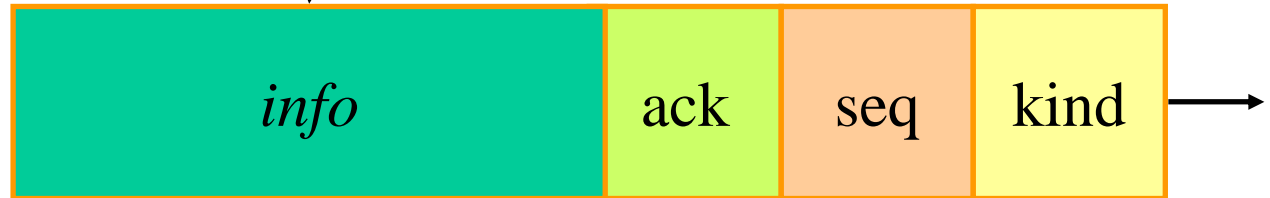

physical layer

```
/* Protocol 1 (utopia) provides for data transmission in one direction only, from
sender to receiver. The communication channel is assumed to be error free,
and the receiver is assumed to be able to process all the input infinitely quickly.
Consequently, the sender just sits in a loop pumping data out onto the line as
fast as it can. */
```

```
typedef enum {frame arrival} event type;
#include "protocol.h"
```

```
void sender1(void)
{
    frame s; /* buffer for an outbound frame */
    packet buffer; /* buffer for an outbound packet */

    while (true) {
        from_network_layer(&buffer); /* go get something to send */
        s.info = buffer; /* copy it into s for transmission */
        to_physical_layer(&s); /* send it on its way */
    } /* Tomorrow, and tomorrow, and tomorrow,
        Creeps in this petty pace from day to day
        To the last syllable of recorded time
        - Macbeth, V, v */
}
```

```
void receiver1(void)
{
    frame r;
    event_type event; /* filled in by wait, but not used here */

    while (true) {
        wait_for_event(&event); /* only possibility is frame_arrival */
        from_physical_layer(&r); /* go get the inbound frame */
        to_network_layer(&r.info); /* pass the data to the network layer */
    }
}
```

# Figure 3-10

## Unrestricted Simplex Protocol



# Figure 3-11

# Simplex Stop-and- Wait Protocol

/\* Protocol 2 (stop-and-wait) also provides for a one-directional flow of data from sender to receiver. The communication channel is once again assumed to be error free, as in protocol 1. However, this time, the receiver has only a finite buffer capacity and a finite processing speed, so the protocol must explicitly prevent the sender from flooding the receiver with data faster than it can be handled. \*/

```
typedef enum {frame_arrival} event_type;
#include "protocol.h"

void sender2(void)
{
    frame s;                /* buffer for an outbound frame */
    packet buffer;          /* buffer for an outbound packet */
    event_type event;      /* frame_arrival is the only possibility */

    while (true) {
        from_network_layer(&buffer); /* go get something to send */
        s.info = buffer;           /* copy it into s for transmission */
        to_physical_layer(&s);    /* bye bye little frame */
        wait_for_event(&event);  /* do not proceed until given the go ahead */
    }
}

void receiver2(void)
{
    frame r, s;             /* buffers for frames */
    event_type event;      /* frame_arrival is the only possibility */
    while (true) {
        wait_for_event(&event); /* only possibility is frame_arrival */
        from_physical_layer(&r); /* go get the inbound frame */
        to_network_layer(&r.info); /* pass the data to the network layer */
        to_physical_layer(&s);    /* send a dummy frame to awaken sender */
    }
}
```

# Ambiguities with Stop-and-Wait [unnumbered frames]

(a) Frame 1 lost

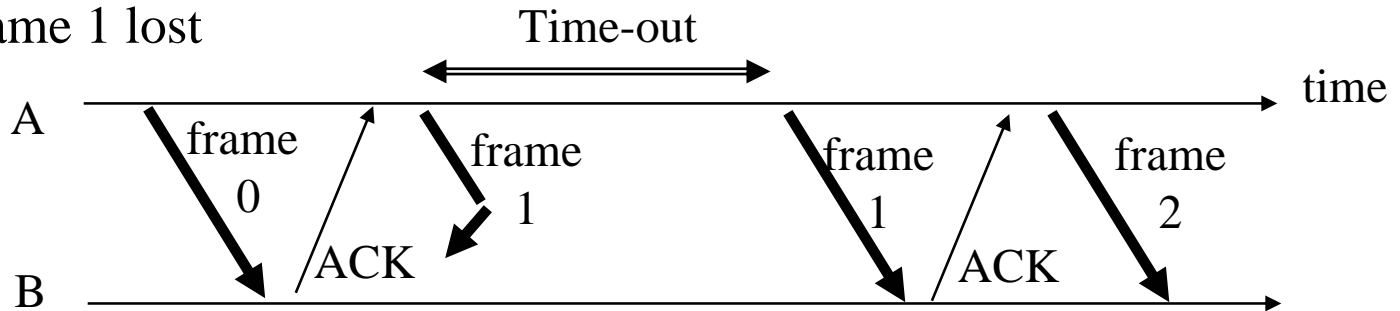

(b) ACK lost

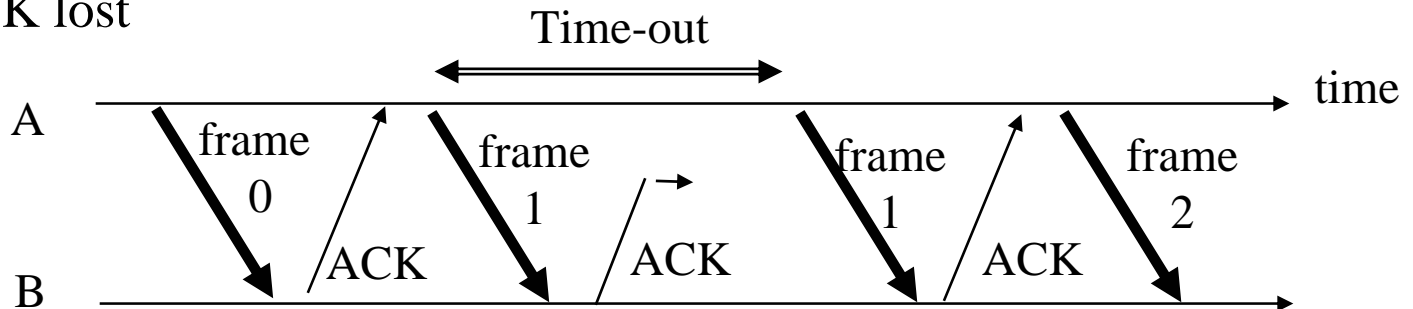

In parts (a) and (b) transmitting station A acts the same way, but part (b) receiving station B accepts frame 1 twice.

# State Machine for Stop-and-Wait

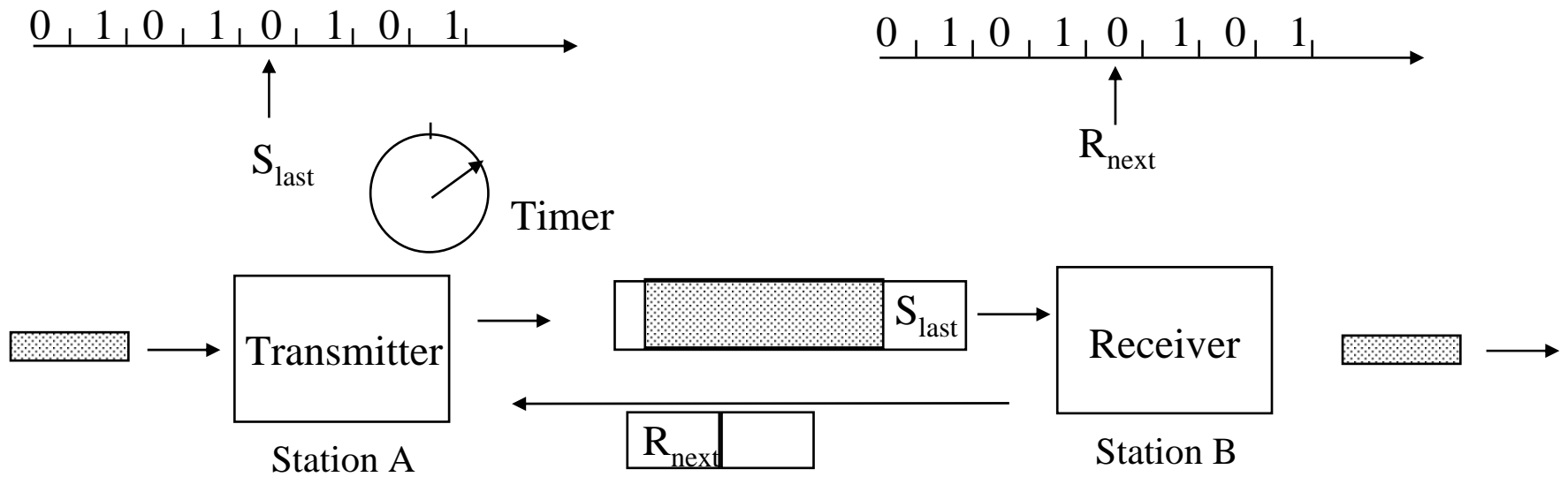

Global State:  
 $(S_{last}, R_{next})$

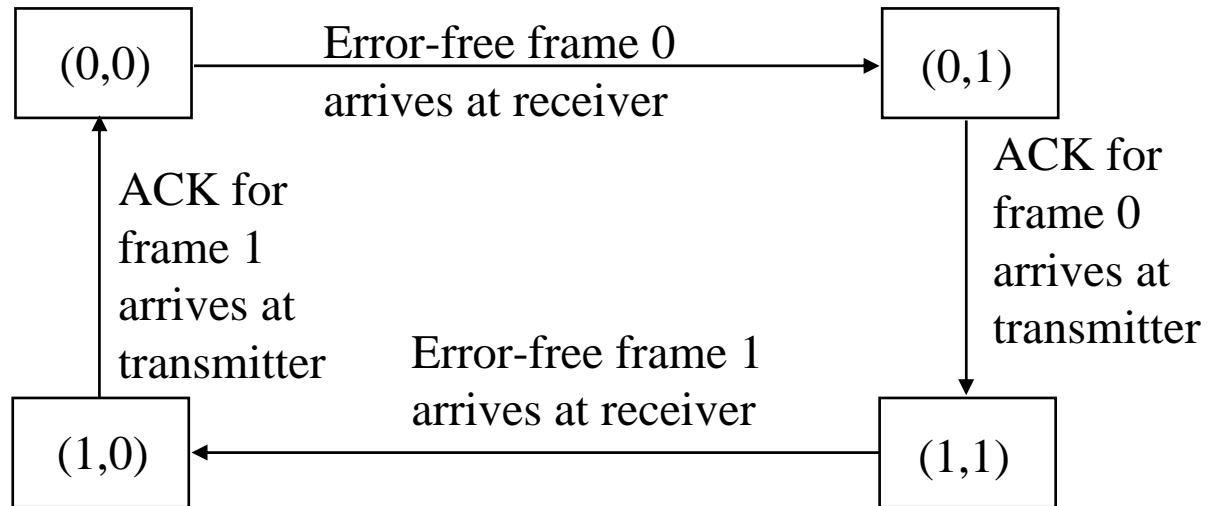

```

#define MAX_SEQ 1
typedef enum {frame_arrival, cksum_err, timeout} event_type;
include "protocol.h"
void sender_par (void)
{
    seq_nr next_frame_to_send;
    frame s;
    packet buffer;
    event_type event;
    next_frame_to_send = 0;
    from_network_layer (&buffer);
    while (true)
    {
        s.info = buffer;
        s.seq = next_frame_to_send;
        to_physical_layer (&s);
        start_timer (s.seq);
        wait_for_event(&event);
        if (event == frame_arrival) {
            from_network_layer (&buffer);
            inc (next_frame_to_send);
        }
    }
}

```

**Protocol 3**  
**(PAR) Positive ACK**  
**with Retransmission**  
**[Old Tanenbaum Version]**

```

void receiver_par (void)
{
  seq_nr next_frame_to_send;
  frame r, s;
  event_type event;
  frame_expected = 0;
  while (true)
  {
    wait_for_event (&event);
    if (event == frame_arrival)
    {
      from_physical_layer (&r);
      if (r.seq == frame_expected) {
        to_network_layer(&r.info);
        inc (frame_expected);
      }
      to_physical_layer (&s);
    }
  }
}

```

**Protocol 3  
(PAR) Positive ACK  
with Retransmission  
[Old Tanenbaum Version]**

**/\* Note – no sequence number on ACK \*/**



# PAR [OLD] problem

Ambiguities when ACKs are not numbered

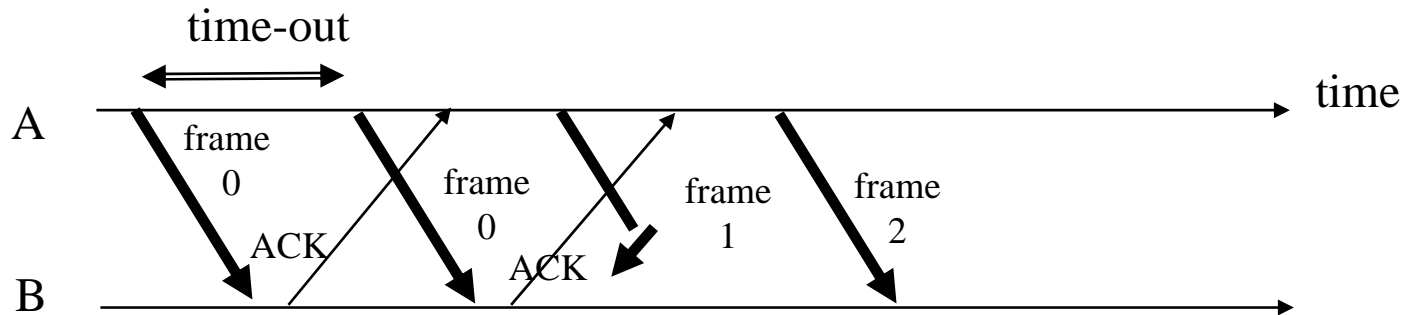

Transmitting station A misinterprets duplicate ACKs

# PAR Simplex Protocol for a Noisy Channel

```
/* Protocol 3 (par) allows unidirectional data flow over an unreliable channel. */
#define MAX_SEQ 1 /* must be 1 for protocol 3 */
typedef enum {frame_arrival, cksum_err, timeout} event_type;
#include "protocol.h"

void sender3(void)
{
    seq_nr next_frame_to_send; /* seq number of next outgoing frame */
    frame s; /* scratch variable */
    packet buffer; /* buffer for an outbound packet */
    event_type event;

    next_frame_to_send = 0; /* initialize outbound sequence numbers */
    from_network_layer(&buffer); /* fetch first packet */
    while (true) {
        s.info = buffer; /* construct a frame for transmission */
        s.seq = next_frame_to_send; /* insert sequence number in frame */
        to_physical_layer(&s); /* send it on its way */
        start_timer(s.seq); /* if answer takes too long, time out */
        wait_for_event(&event); /* frame_arrival, cksum_err, timeout */
        if (event == frame_arrival) {
            from_physical_layer(&s); /* get the acknowledgement */
            if (s.ack == next_frame_to_send) {
                stop_timer(s.ack); /* turn the timer off */
                from_network_layer(&buffer); /* get the next one to send */
                inc(next_frame_to_send); /* invert next_frame_to_send */
            }
        }
    }
}
```

Figure 3-12.A Positive Acknowledgement with Retransmission protocol.

# A Simplex Protocol for a Noisy Channel

```
void receiver3(void)
{
    seq_nr frame_expected;
    frame r, s;
    event_type event;

    frame_expected = 0;
    while (true) {
        wait_for_event(&event);           /* possibilities: frame_arrival, cksum_err */
        if (event == frame_arrival) {    /* a valid frame has arrived. */
            from_physical_layer(&r);     /* go get the newly arrived frame */
            if (r.seq == frame_expected) /* this is what we have been waiting for. */
                to_network_layer(&r.info); /* pass the data to the network layer */
            inc(frame_expected);         /* next time expect the other sequence nr */
        }
        s.ack = 1 - frame_expected;      /* tell which frame is being acked */
        to_physical_layer(&s);          /* send acknowledgement */
    }
}
```

Figure 3-12. A positive acknowledgement with retransmission protocol.

# Sliding Window Protocols

## [Tanenbaum]

- Must be able to transmit data in both directions.
- Choices for utilization of the reverse channel:
  - mix DATA frames with ACK frames.
  - *Piggyback* the ACK
    - Receiver waits for DATA traffic in the opposite direction.
    - Use the ACK field in the frame header to send *sequence number* of frame being ACKed.
  - → better use of the channel capacity.

# Sliding Window Protocols

- ACKs introduce a new issue – how long does receiver wait before sending ONLY an ACK frame.
  - ➔ We need an *ACKTimer*!!
  - ➔ The sender *timeout period* needs to be set longer.
- The protocol must deal with the **premature timeout problem** and be “robust” under pathological conditions.

# Sliding Window Protocols

Each outbound frame must contain a *sequence number*. With  $n$  bits for the sequence number field,  $\text{maxseq} = 2^n - 1$  and the numbers range from 0 to maxseq.

*Sliding window* :: the sender has a **window** of frames and maintains a list of consecutive sequence numbers for frames that it is permitted to send without waiting for ACKs.

The receiver has a **window** that is a list of frame sequence numbers it is permitted to accept.

*Note – sending and receiving windows do NOT have to be the same size.*

The windows can be fixed size or dynamically growing and shrinking.

# Sliding Window Protocols

- The Host is oblivious to sliding windows and the message order at the transport layer is maintained.

**sender's window** :: *frames sent but not yet ACKed.*

- new packets from the Host cause the upper edge inside the sender's window to be incremented.
- acknowledged frames from the receiver cause the lower edge inside the sender's window to be incremented.

# Sliding Window Protocols

- All frames in the sender's window must be saved for possible retransmission and we need one timer per frame in the window.
- If the maximum sender window size is  $B$ , the sender needs at least  $B$  buffers.
- If the **sender's window** gets full (i.e., it reaches the maximum window size, the protocol must shut off the Host (the network layer) until buffers become available.



# Sliding Window Protocols

## receiver's window

- Frames received with sequence numbers outside the **receiver's window** are not accepted.
- The receiver's window size is normally *static*.  
The set of acceptable sequence numbers is rotated as “acceptable” frames arrive.

a receiver's window size = 1 → *the protocol only accepts frames in order.*

This scheme is referred to as **Go Back N**.

## Two Standard Ways to ACK

1. The ACK sequence number indicates *the last frame successfully received*.

**- OR -**

2. ACK sequence number indicates *the next frame the receiver expects to receive*.

*Both of these can be strictly individual ACKs or represent cumulative ACKing.*

Cumulative ACKing is the most common technique.

# One-Bit Sliding Window Protocol

```
/* Protocol 4 (sliding window) is bidirectional. */

#define MAX_SEQ 1 /* must be 1 for protocol 4 */
typedef enum {frame_arrival, cksum_err, timeout} event_type;
#include "protocol.h"
void protocol4 (void)
{
    seq_nr next_frame_to_send; /* 0 or 1 only */
    seq_nr frame_expected; /* 0 or 1 only */
    frame r, s; /* scratch variables */
    packet buffer; /* current packet being sent */
    event_type event;

    next_frame_to_send = 0; /* next frame on the outbound stream */
    frame_expected = 0; /* frame expected next */
    from_network_layer(&buffer); /* fetch a packet from the network layer */
    s.info = buffer; /* prepare to send the initial frame */
    s.seq = next_frame_to_send; /* insert sequence number into frame */
    s.ack = 1 - frame_expected; /* piggybacked ack */
    to_physical_layer(&s); /* transmit the frame */
    start_timer(s.seq); /* start the timer running */

    while (true) {
        wait_for_event(&event); /* frame_arrival, cksum_err, or timeout */
        if (event == frame_arrival) { /* a frame has arrived undamaged. */
            from_physical_layer(&r); /* go get it */
            if (r.seq == frame_expected) { /* handle inbound frame stream. */
                to_network_layer(&r.info); /* pass packet to network layer */
                inc(frame_expected); /* invert seq number expected next */
            }
            if (r.ack == next_frame_to_send) { /* handle outbound frame stream. */
                stop_timer(r.ack); /* turn the timer off */
                from_network_layer(&buffer); /* fetch new pkt from network layer */
                inc(next_frame_to_send); /* invert sender's sequence number */
            }
        }
        s.info = buffer; /* construct outbound frame */
        s.seq = next_frame_to_send; /* insert sequence number into it */
        s.ack = 1 - frame_expected; /* seq number of last received frame */
        to_physical_layer(&s); /* transmit a frame */
        start_timer(s.seq); /* start the timer running */
    }
}
```

Figure 3-14. A 1-bit sliding window protocol.



# Go Back N

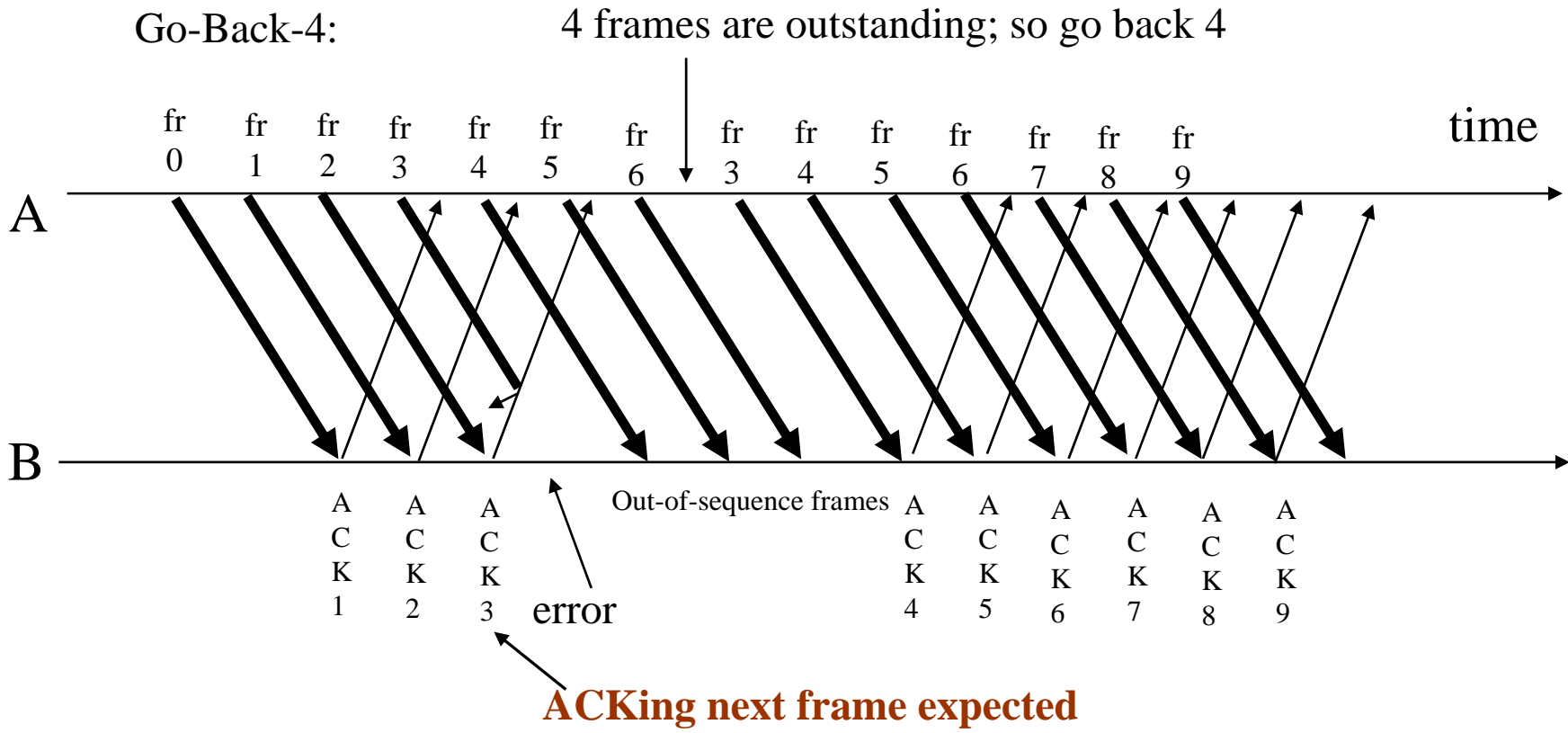



*/\* Protocol 5 (go back n) allows multiple outstanding frames. The sender may transmit up to MAX\_SEQ frames without waiting for an ack. In addition, unlike in the previous protocols, the network layer is not assumed to have a new packet all the time. Instead, the network layer causes a network\_layer\_ready event when there is a packet to send.*

```

#define MAX_SEQ 7 /* should be 2^n - 1 */
typedef enum {frame_arrival, cksum_err, timeout, network_layer_ready} event_type;
#include "protocol.h"

static boolean between(seq_nr a, seq_nr b, seq_nr c)
{
/* Return true if a <= b < c circularly; false otherwise. */
  if (((a <= b) && (b < c)) || ((c < a) && (a <= b)) || ((b < c) && (c < a)))
    return(true);
  else
    return(false);
}

static void send_data(seq_nr frame_nr, seq_nr frame_expected, packet buffer[])
{
/* Construct and send a data frame. */
  frame s; /* scratch variable */

  s.info = buffer[frame_nr]; /* insert packet into frame */
  s.seq = frame_nr; /* insert sequence number into frame */
  s.ack = (frame_expected + MAX_SEQ) % (MAX_SEQ + 1); /* piggyback ack */
  to_physical_layer(&s); /* transmit the frame */
  start_timer(frame_nr); /* start the timer running */
}

void protocol5(void)
{
  seq_nr next_frame_to_send; /* MAX_SEQ > 1; used for outbound stream */
  seq_nr ack_expected; /* oldest frame as yet unacknowledged */
  seq_nr frame_expected; /* next frame expected on inbound stream */
  frame r; /* scratch variable */
  packet buffer[MAX_SEQ + 1]; /* buffers for the outbound stream */
  seq_nr nbuffered; /* # output buffers currently in use */
  seq_nr i; /* used to index into the buffer array */
  event_type event;

  enable_network_layer(); /* allow network_layer_ready events */
  ack_expected = 0; /* next ack expected inbound */
  next_frame_to_send = 0; /* next frame going out */
  frame_expected = 0; /* number of frame expected inbound */
  nbuffered = 0; /* initially no packets are buffered */
}

```

```

while (true) {
    wait_for_event(&event);                /* four possibilities: see event_type above */

    switch(event) {
        case network_layer_ready:          /* the network layer has a packet to send */
            /* Accept, save, and transmit a new frame. */
            from_network_layer(&buffer[next_frame_to_send]); /* fetch new packet */
            nbuffered = nbuffered + 1;     /* expand the sender's window */
            send_data(next_frame_to_send, frame_expected, buffer); /* transmit the frame */
            inc(next_frame_to_send);       /* advance sender's upper window edge */
            break;

        case frame_arrival:                /* a data or control frame has arrived */
            from_physical_layer(&r);       /* get incoming frame from physical layer */

            if (r.seq == frame_expected) {
                /* Frames are accepted only in order. */
                to_network_layer(&r.info); /* pass packet to network layer */
                inc(frame_expected);      /* advance lower edge of receiver's window */
            }

            /* Ack n implies n - 1, n - 2, etc. Check for this. */
            while (between(ack_expected, r.ack, next_frame_to_send)) {
                /* Handle piggybacked ack. */
                nbuffered = nbuffered - 1; /* one frame fewer buffered */
                stop_timer(ack_expected); /* frame arrived intact; stop timer */
                inc(ack_expected);        /* contract sender's window */
            }
            break;

        case cksum_err: break;             /* just ignore bad frames */

        case timeout:                       /* trouble; retransmit all outstanding frames */
            next_frame_to_send = ack_expected; /* start retransmitting here */
            for (i = 1; i <= nbuffered; i++) {
                send_data(next_frame_to_send, frame_expected, buffer); /* resend frame */
                inc(next_frame_to_send); /* prepare to send the next one */
            }
    }

    if (nbuffered < MAX_SEQ)
        enable_network_layer();
    else
        disable_network_layer();
}
}

```

Figure 3-17. A sliding window protocol using go back n.

# Selective Repeat with NAK error recovery

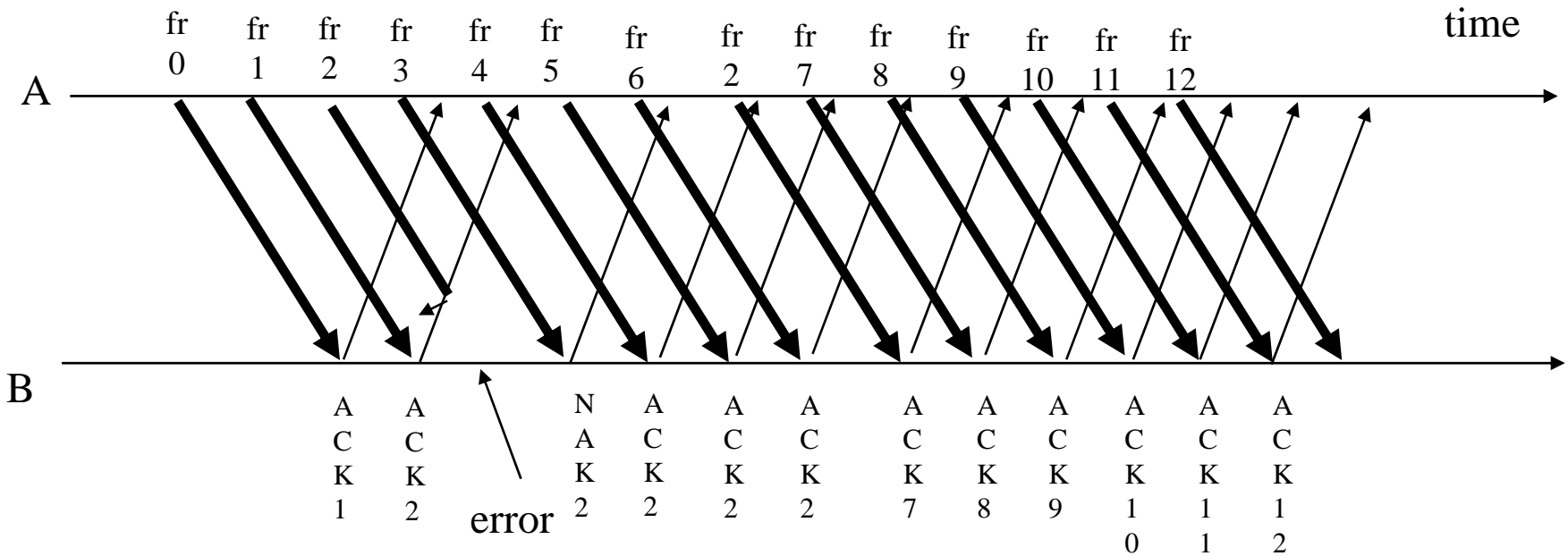



```

/* Protocol 6 (selective repeat) accepts frames out of order but passes packets to the
network layer in order. Associated with each outstanding frame is a timer. When the timer
expires, only that frame is retransmitted, not all the outstanding frames, as in protocol 5. */

#define MAX_SEQ 7                               /* should be 2^n - 1 */
#define NR_BUFS ((MAX_SEQ + 1)/2)
typedef enum {frame_arrival, cksum_err, timeout, network_layer_ready, ack_timeout} event_type;
#include "protocol.h"
boolean no_nak = true;                          /* no nak has been sent yet */
seq_nr oldest_frame = MAX_SEQ + 1;             /* initial value is only for the simulator */

static boolean between(seq_nr a, seq_nr b, seq_nr c)
{
/* Same as between in protocol5, but shorter and more obscure. */
return ((a <= b) && (b < c)) || ((c < a) && (a <= b)) || ((b < c) && (c < a));
}

static void send_frame(frame_kind fk, seq_nr frame_nr, seq_nr frame_expected, packet buffer[])
{
/* Construct and send a data, ack, or nak frame. */
frame s;                                       /* scratch variable */

s.kind = fk;                                  /* kind == data, ack, or nak */
if (fk == data) s.info = buffer[frame_nr % NR_BUFS];
s.seq = frame_nr;                             /* only meaningful for data frames */
s.ack = (frame_expected + MAX_SEQ) % (MAX_SEQ + 1);
if (fk == nak) no_nak = false;               /* one nak per frame, please */
to_physical_layer(&s);                       /* transmit the frame */
if (fk == data) start_timer(frame_nr % NR_BUFS);
stop_ack_timer();                             /* no need for separate ack frame */
}

void protocol6(void)
{
seq_nr ack_expected;                          /* lower edge of sender's window */
seq_nr next_frame_to_send;                   /* upper edge of sender's window + 1 */
seq_nr frame_expected;                      /* lower edge of receiver's window */
seq_nr too_far;                             /* upper edge of receiver's window + 1 */
int i;                                       /* index into buffer pool */
frame r;                                     /* scratch variable */
packet out_buf[NR_BUFS];                   /* buffers for the outbound stream */
packet in_buf[NR_BUFS];                    /* buffers for the inbound stream */
boolean arrived[NR_BUFS];                  /* inbound bit map */
seq_nr nbuffered;                          /* how many output buffers currently used */

enable_network_layer();                    /* initialize */
ack_expected = 0;                          /* next ack expected on the inbound stream */
next_frame_to_send = 0;                    /* number of next outgoing frame */
frame_expected = 0;
too_far = NR_BUFS;
nbuffered = 0;
/* initially no packets are buffered */
for (i = 0; i < NR_BUFS; i++) arrived[i] = false;
}

```

```

while (true) {
wait_for_event(&event);                               /* five possibilities: see event_type above */
switch(event) {
case network_layer_ready:                             /* accept, save, and transmit a new frame */
nbuffered = nbuffered + 1;                             /* expand the window */
from_network_layer(&out_buf[next_frame_to_send % NR_BUFS]); /* fetch new packet */
send_frame(data, next_frame_to_send, frame_expected, out_buf); /* transmit the frame */
inc(next_frame_to_send);                               /* advance upper window edge */
break;

case frame_arrival:                                  /* a data or control frame has arrived */
from_physical_layer(&r);                               /* fetch incoming frame from physical layer */
if (r.kind == data) {
/* An undamaged frame has arrived. */
if ((r.seq != frame_expected) && no_nak)
send_frame(nak, 0, frame_expected, out_buf); else start_ack_timer();
if (between(frame_expected,r.seq,too_far) && (arrived[r.seq%NR_BUFS]==false)) {
/* Frames may be accepted in any order. */
arrived[r.seq % NR_BUFS] = true; /* mark buffer as full */
in_buf[r.seq % NR_BUFS] = r.info; /* insert data into buffer */
while (arrived[frame_expected % NR_BUFS]) {
/* Pass frames and advance window. */
to_network_layer(&in_buf[frame_expected % NR_BUFS]);
no_nak = true;
arrived[frame_expected % NR_BUFS] = false;
inc(frame_expected); /* advance lower edge of receiver's window */
inc(too_far); /* advance upper edge of receiver's window */
start_ack_timer(); /* to see if a separate ack is needed */
}
}
}
if((r.kind==nak) && between(ack_expected,(r.ack+1)%(MAX_SEQ+1),next_frame_to_send))
send_frame(data, (r.ack+1) % (MAX_SEQ + 1), frame_expected, out_buf);

while (between(ack_expected, r.ack, next_frame_to_send)) {
nbuffered = nbuffered - 1; /* handle piggybacked ack */
stop_timer(ack_expected % NR_BUFS); /* frame arrived intact */
inc(ack_expected); /* advance lower edge of sender's window */
}
break;

case cksum_err:
if (no_nak) send_frame(nak, 0, frame_expected, out_buf); /* damaged frame */
break;

case timeout:
send_frame(data, oldest_frame, frame_expected, out_buf); /* we timed out */
break;

case ack_timeout:
send_frame(ack,0,frame_expected, out_buf); /* ack timer expired; send ack */
}
if (nbuffered < NR_BUFS) enable_network_layer(); else disable_network_layer();
}
}

```

**Figure 3-19.** A sliding window protocol using selective repeat.