

CS4514

Computer Networks

Term B06

Professor Bob Kinicki



Course Objectives



Course Objectives

1. To develop an understanding of modern network architectures from a **design** and **performance** perspective.
2. To introduce the student to the major concepts involved in wide-area networks (WANs), local area networks (LANs) and Wireless LANs (WLANs).
3. To clarify network terminology.



Course Objectives

4. To provide an opportunity to do network programming using **TCP/IP**.
5. To give the students experience working in programming teams.
6. To provide a WLAN measurement experience.
7. To expose students to emerging technologies and their potential impact.



Introduction



Network Definitions and Classification

- Preliminary definitions and network terminology
- Sample application paradigms
- Classifying networks by transmission technology
- Classifying networks by size (or scale)
- Classifying networks by topology



Preliminary Definitions

computer network :: [Tanenbaum] a collection of “autonomous” computers interconnected by a single technology.

[LG&W] *communications network* :: a set of equipment and facilities that provide a service.

In a **distributed system** the collection of independent computers appears to its users as a single coherent system.



Client-Server Applications

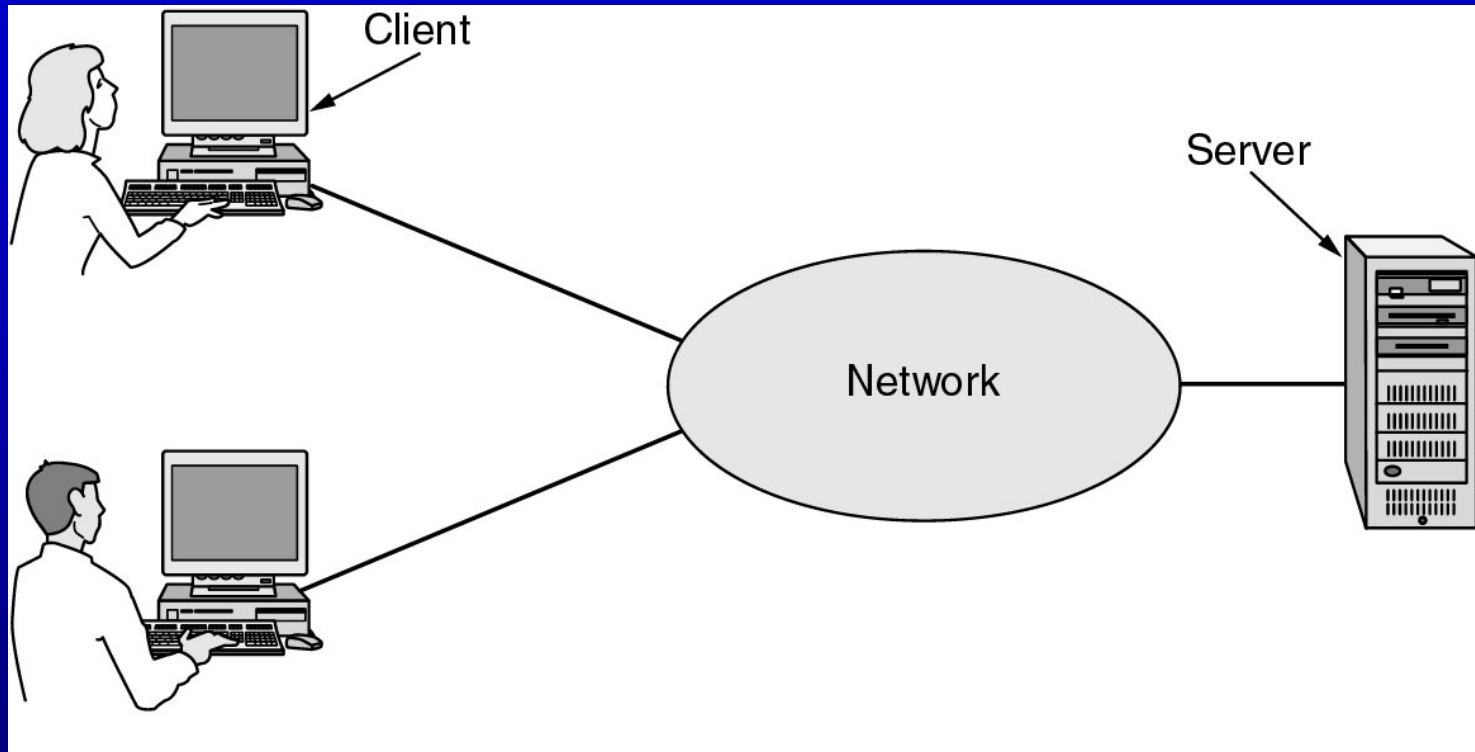

Figure 1.1 A network with two clients and one server.

Client-Server Model

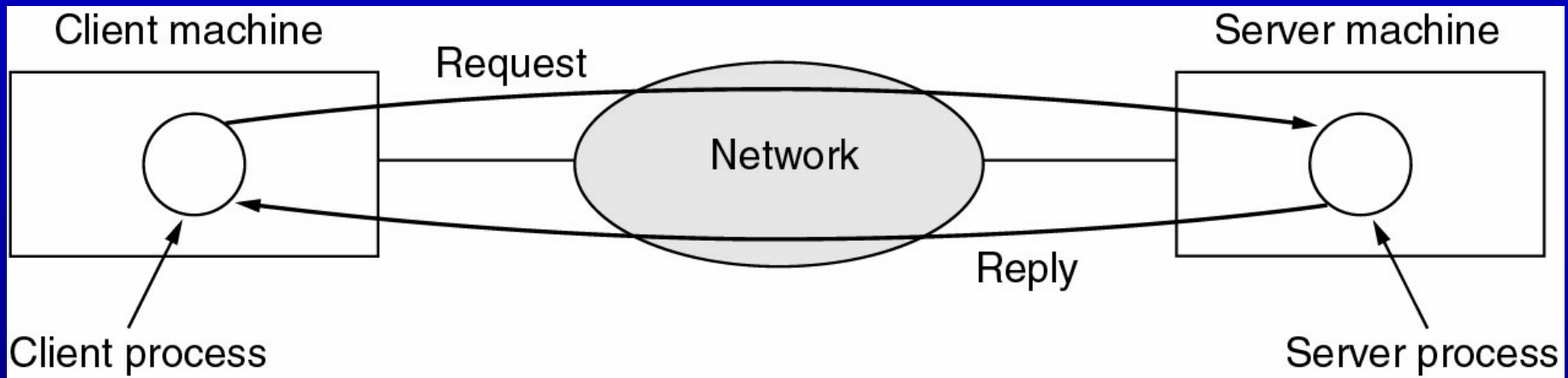

Figure 1-2. The client-server model involves requests and replies.

Peer-to-Peer Applications

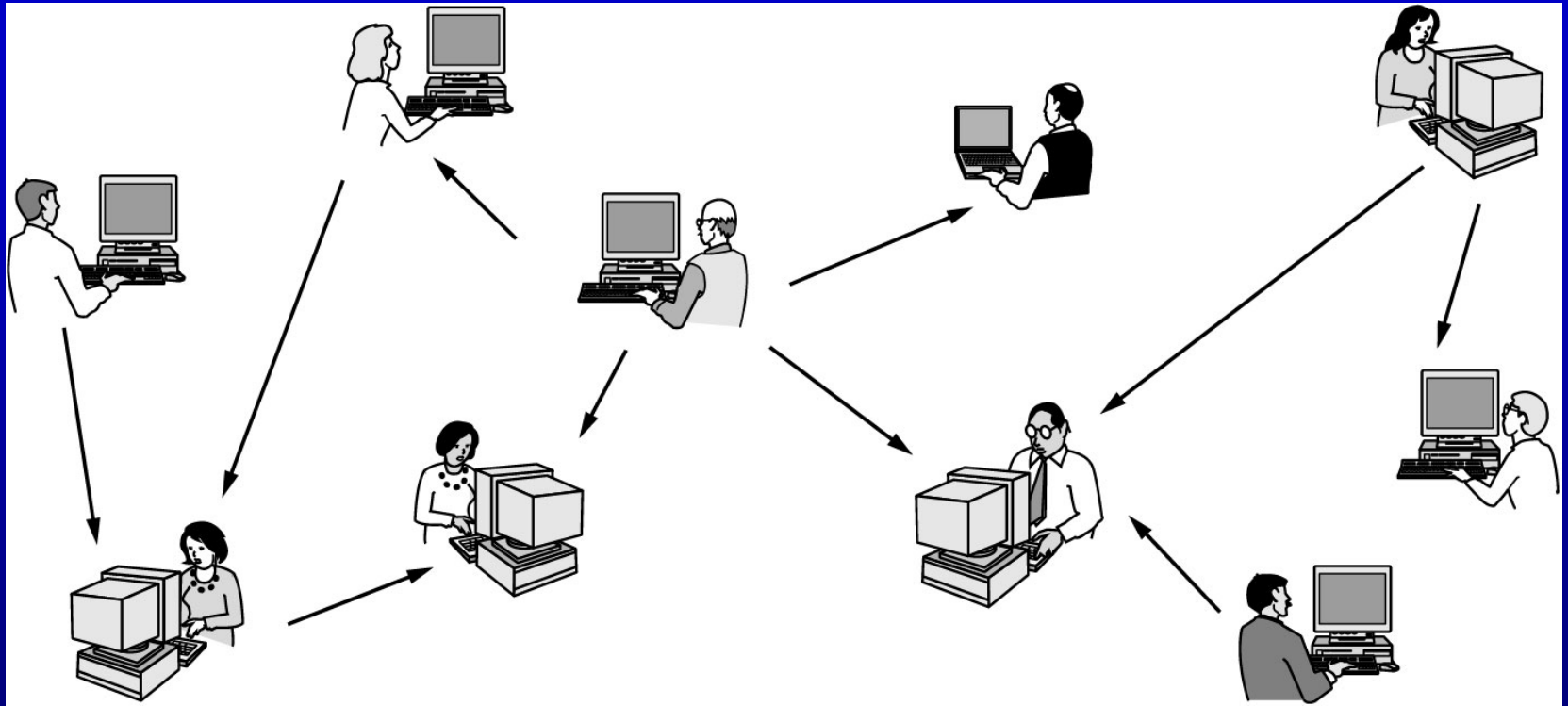
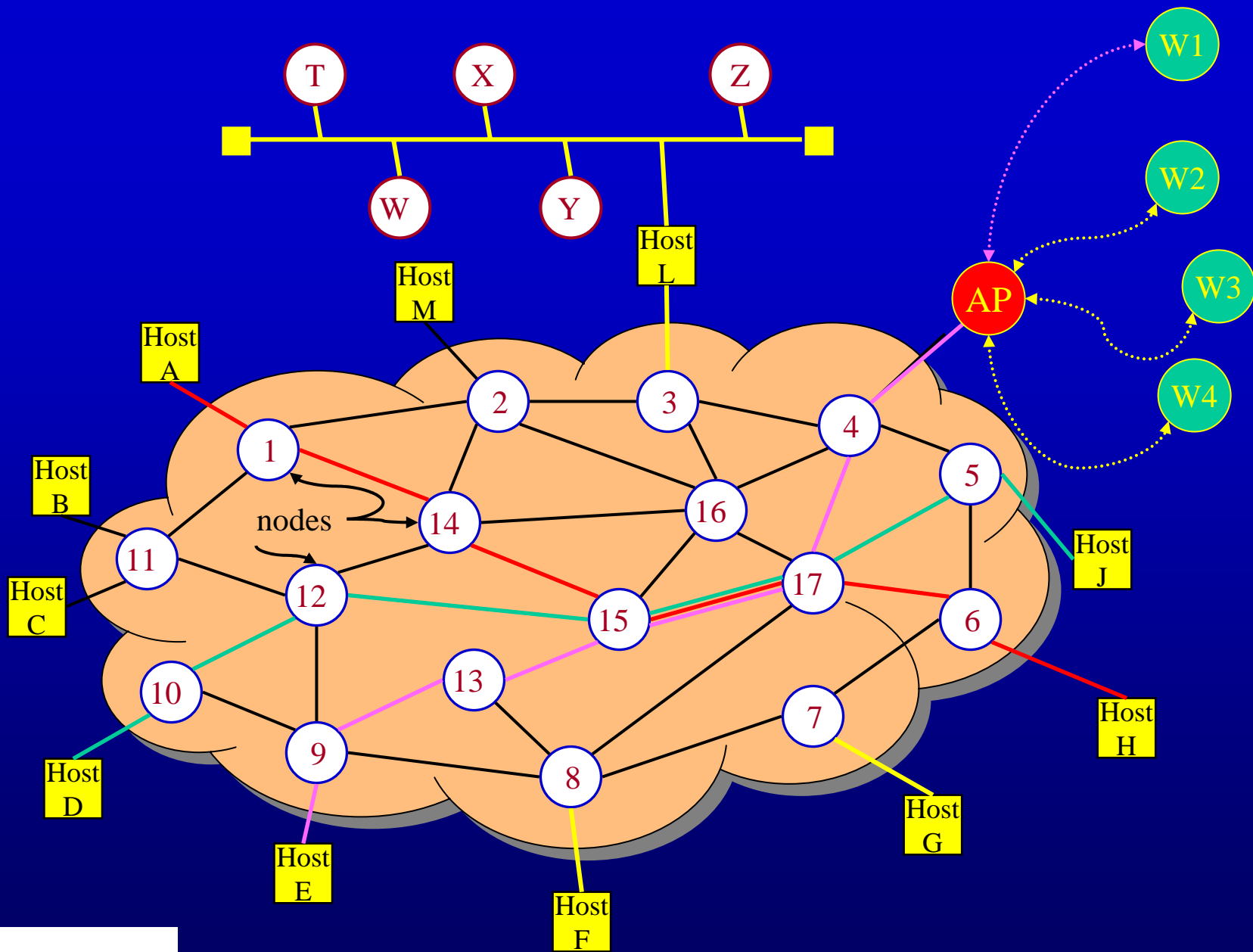

Figure 1.3 In a peer-to-peer system there are no fixed clients and servers.

Mobile Network Users

Wireless	Mobile	Applications
No	No	Desktop computers in offices
No	Yes	A notebook computer used in a hotel room
Yes	No	Networks in older, unwired buildings
Yes	Yes	Portable office; PDA for store inventory

Figure 1-5. Combinations of wireless networks and mobile computing.



Classifying Networks by Transmission Technology

broadcast :: a single communications channel shared by all machines (addresses) on the network. *Broadcast can be both a logical or a physical concept (e.g. Media Access Control (MAC) sublayer).*

multicast :: communications to a specified group. *This requires a group address (e.g. – multimedia multicast).*

point-to-point :: connections made via *links* between pairs of nodes.



Network Classification by Size

Interprocessor distance	Processors located in same	Example
1 m	Square meter	Personal area network
10 m	Room	
100 m	Building	
1 km	Campus	
10 km	City	Local area network
100 km	Country	Metropolitan area network
1000 km	Continent	
10,000 km	Planet	Wide area network
		The Internet

Figure 1-6. Classification of interconnected processors by scale.

Network Classification by Size

- **LANs** {Local Area Networks}
 - Wired LANs: typically physically broadcast at the MAC layer (e.g., Ethernet, Token Ring)
 - Wireless LANs
- **MANs** {Metropolitan Area Networks}
 - campus networks connecting LANs logically or physically.
 - often have a backbone (e.g., FDDI and ATM)



Wired LANs

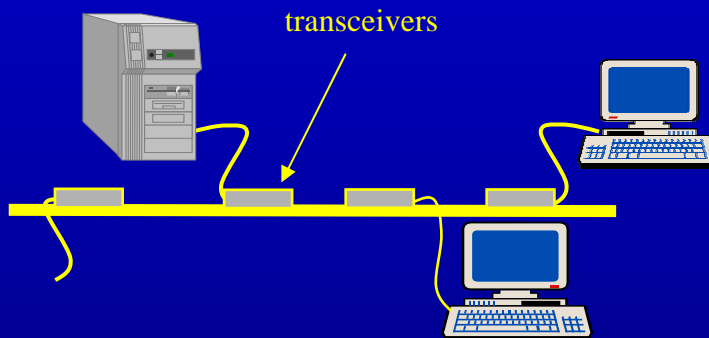

Ethernet bus

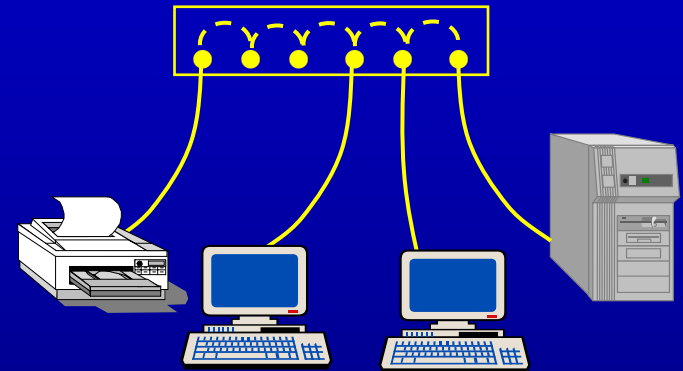

Ethernet hub

Copyright ©2000 The McGraw Hill
Companies

Leon-Garcia & Widjaja: *Communication
Networks*

Figure 1.17

Wireless LANs (WLANs)

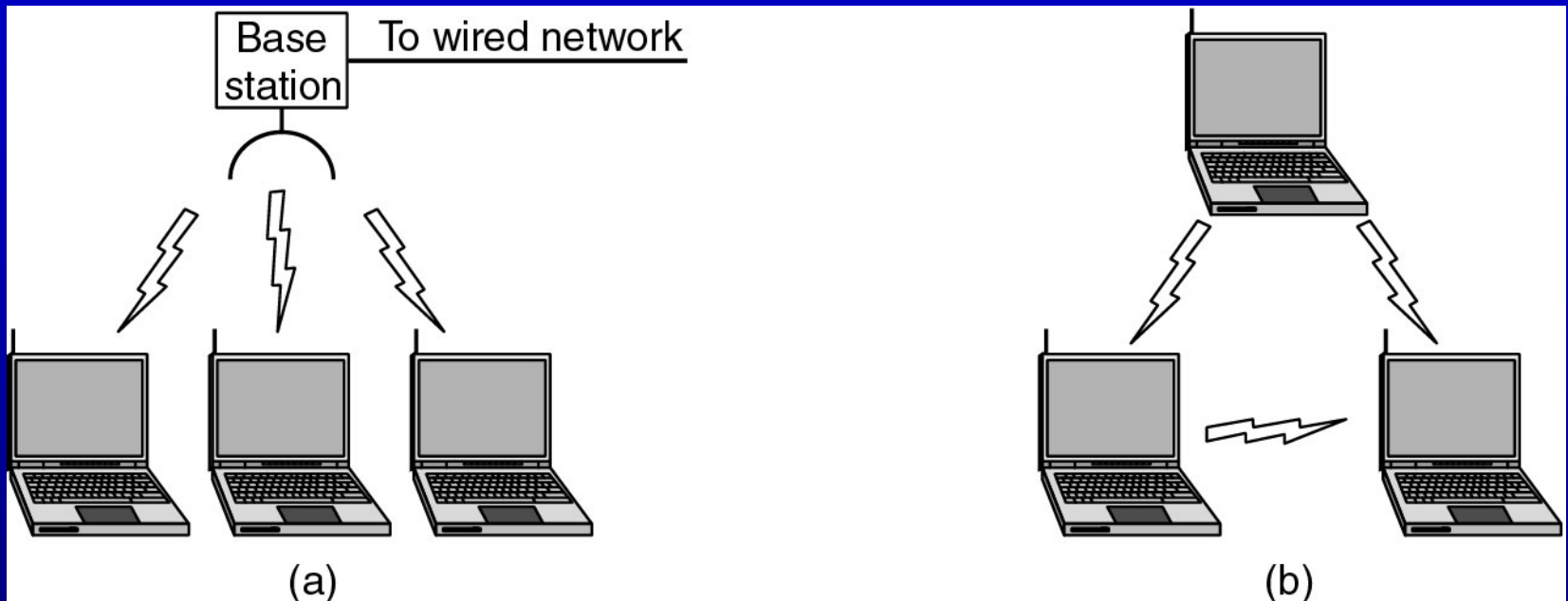

Figure 1-35. (a) Wireless networking with a base station. (b) Ad hoc networking.

Metropolitan Area Networks

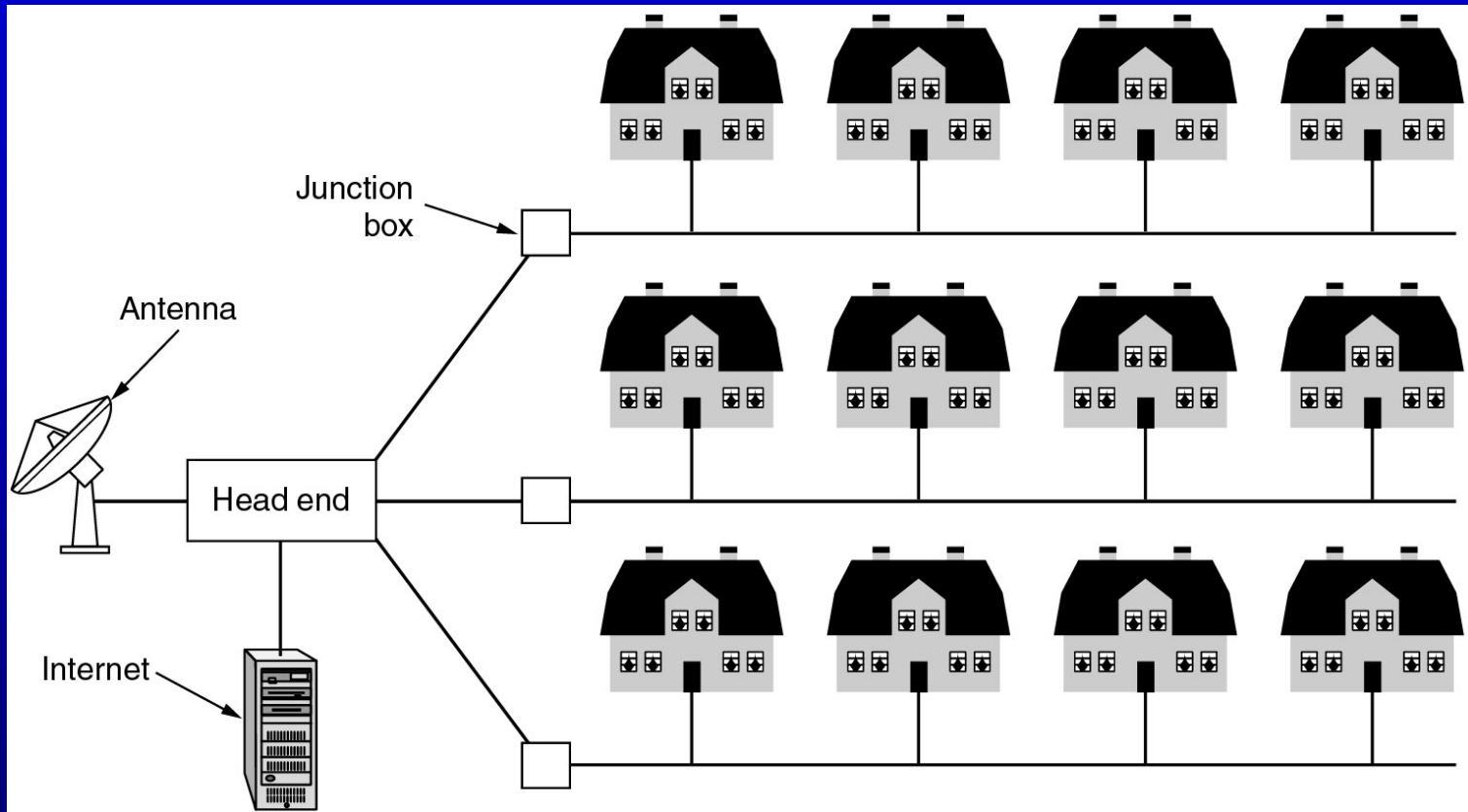
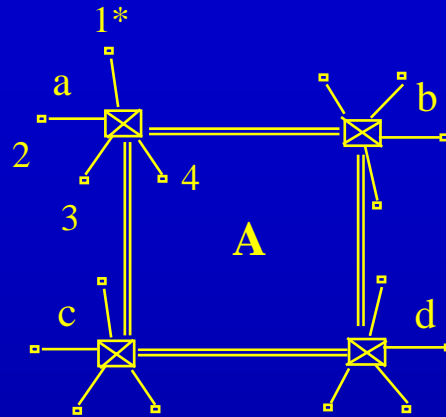

Figure 1-8. A metropolitan area network based on cable TV.

MAN



Metropolitan network **A** consists of access subnetworks a, b, c, d.

Hierarchical Network Topology

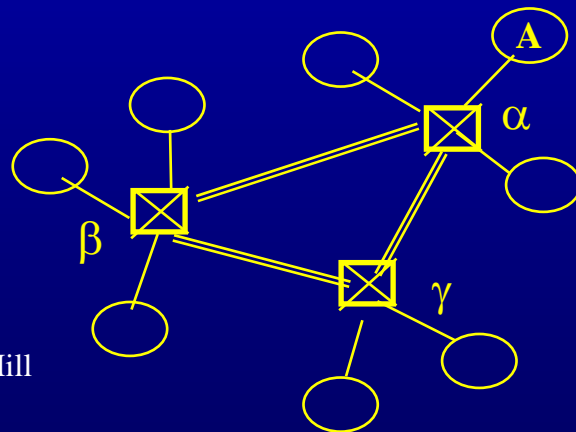

National network consists of regional subnetworks α , β , γ .

Metropolitan network **A** is part of regional subnetwork α .

Copyright ©2000 The McGraw Hill Companies

Leon-Garcia & Widjaja: *Communication Networks*

Figure 1.8



Network Classification by Size

- **WANs** { Wide Area Networks }
 - *also referred to as “point-to-point” networks.*
 - ARPANET → Internet
 - usually hierarchical with a backbone.
 - Enterprise Networks, Autonomous Systems
 - VPNs (Virtual Private Networks).



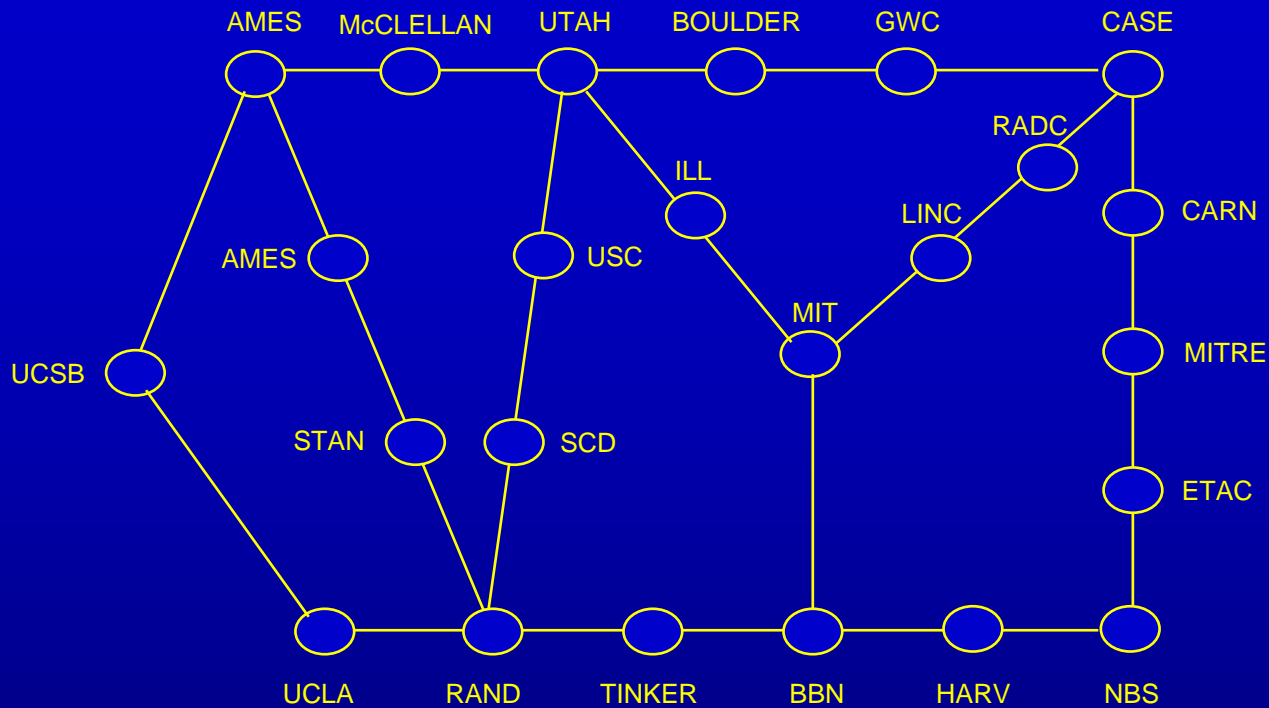

ARPANet circa 1972
a point-to-point network

Copyright ©2000 The McGraw Hill Companies

Leon-Garcia & Widjaja: *Communication Networks*

Figure 1.16



Wide Area Networks (WANs)

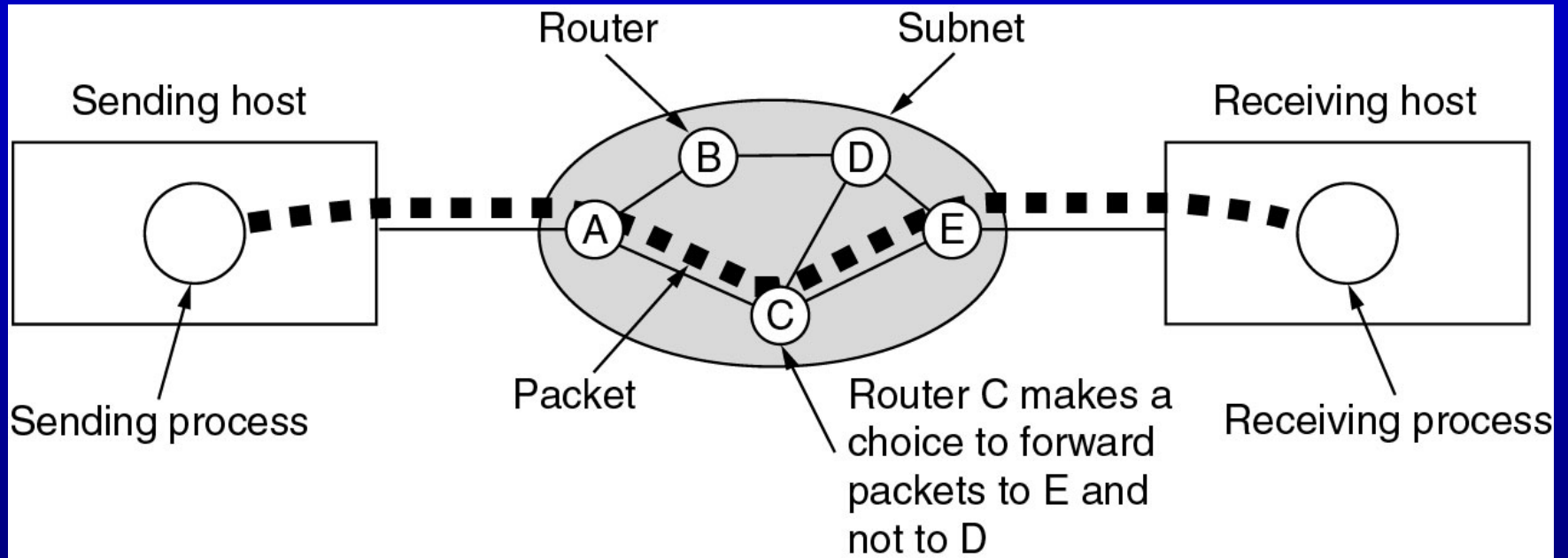
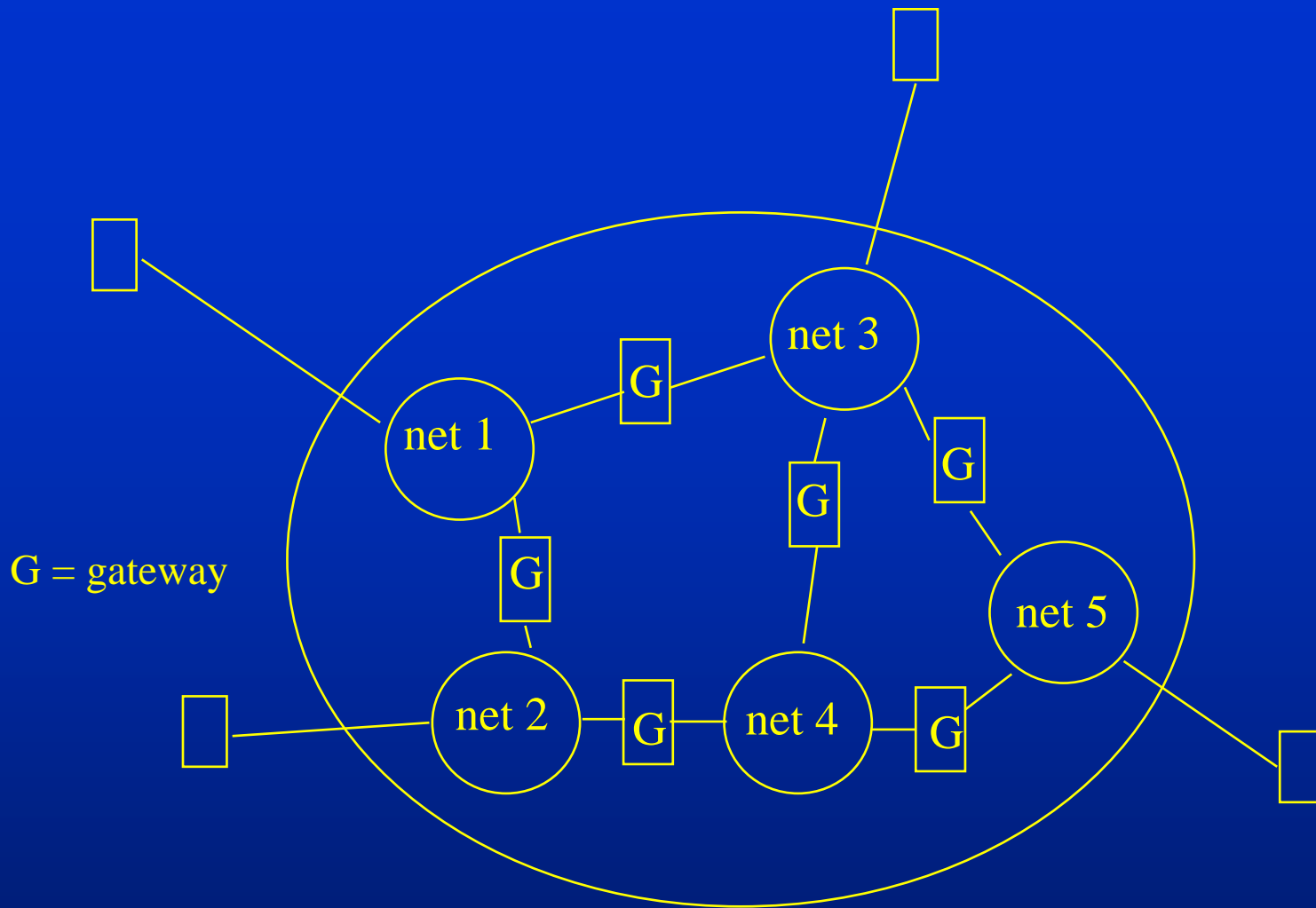

Figure 1-10. A stream of packets from sender to receiver.



internet - a network of networks

Copyright ©2000 The McGraw Hill Companies

Leon-Garcia & Widjaja: *Communication Networks*

Figure 1.18

Networks: Introduction



Network Classification by Topology

Bus

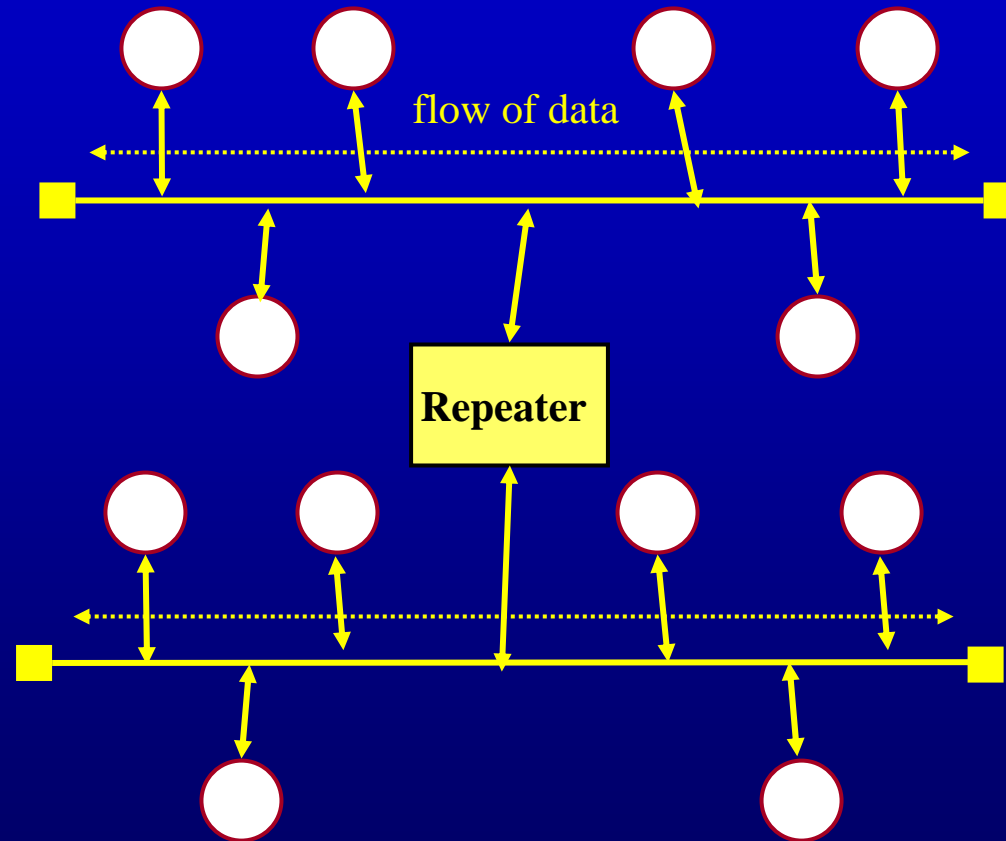

*Bidirectional flow
assumes baseband cable*

Network Classification by Topology

Ring

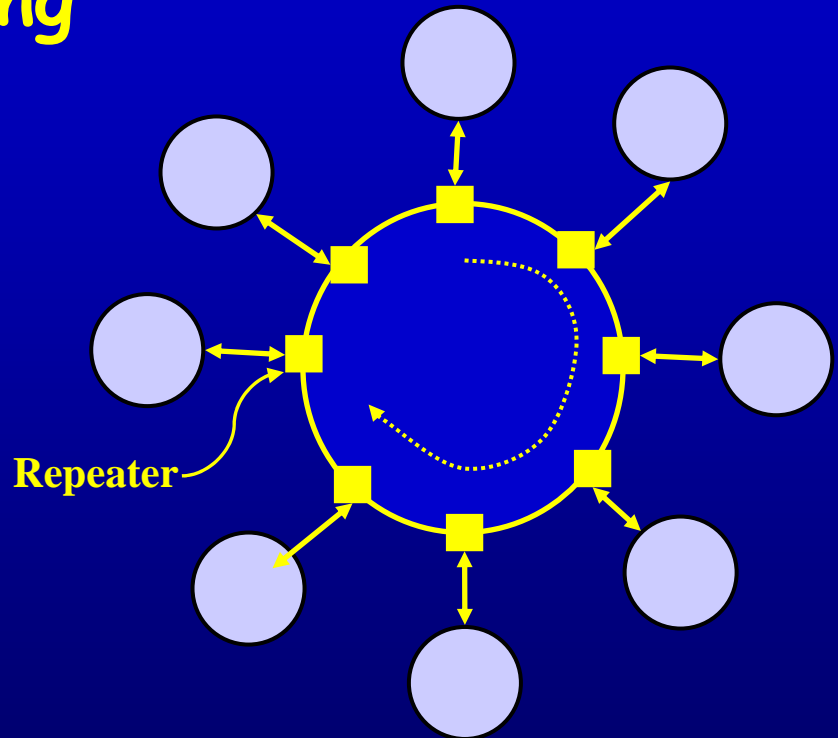
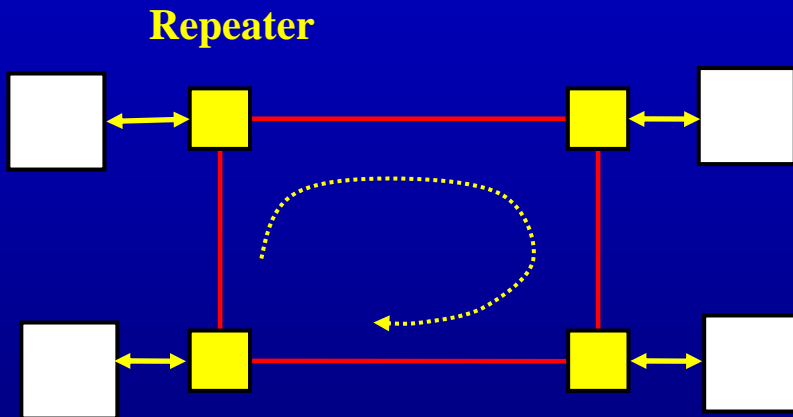

Note - a ring implies unidirectional flow

Network Classification by Topology

Tree

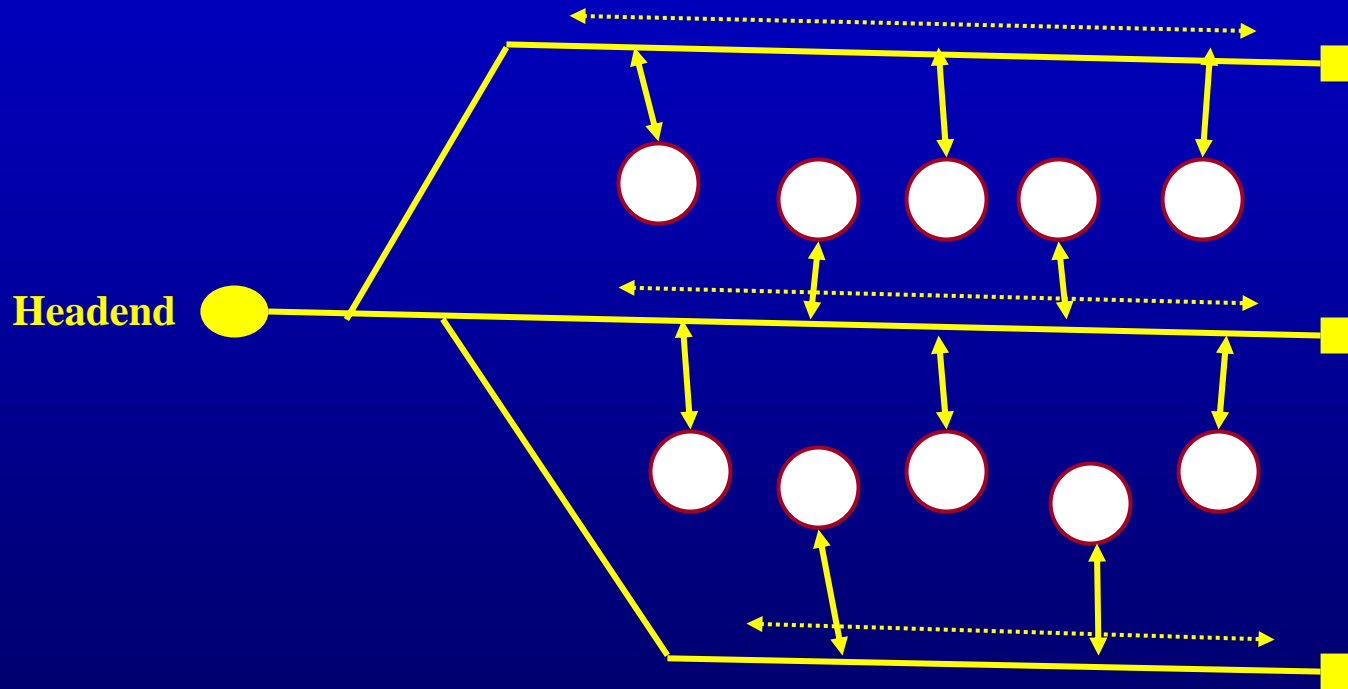

Network Classification by Topology

Star

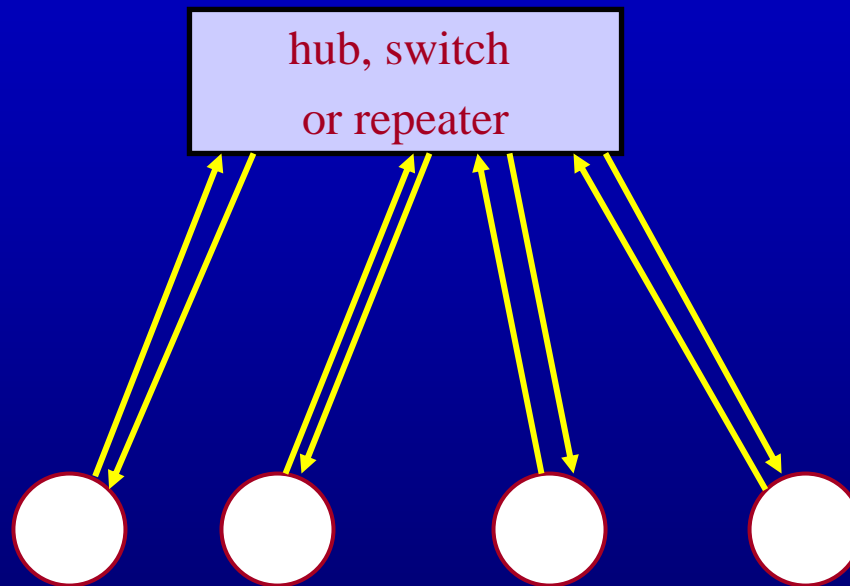

Network Classification by Topology

Star

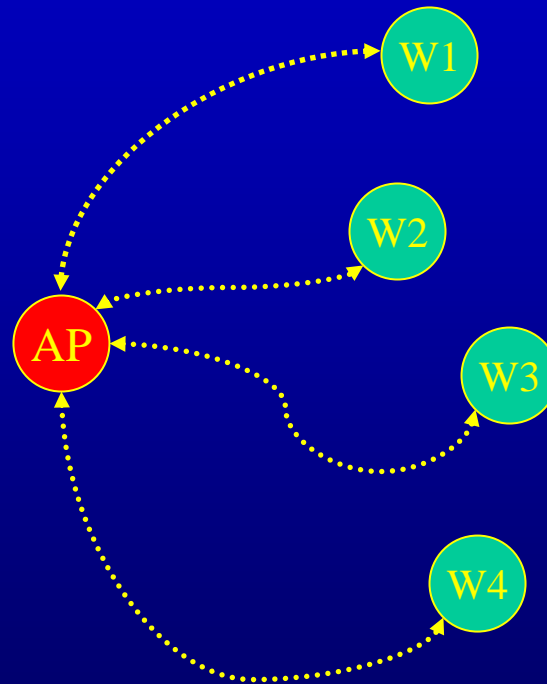

Wireless Infrastructure